

Pos-H

World Best H-Beam certified by POSCO

posco Columbus

CONTENTS

1. KS for Construction Steel Materials	06
2. Pos-H	07
2.1 Optimized Pos-H	09
– Bending member size distribution	10
– Flexural members (734 types)	12
– Asymmetric flexural members (20 types)	30
– Compression members – H shape (75 types)	32
– Compression members – π shape (40 types)	35
2.2 Standardized Pos-H	37
– One-to-one conversion from RH to Pos-H (62 types)	38
– Floor height restriction (22 types)	40
3. Structural Design – How to use MIDAS gen	41
4. Economic Analysis of Pos-H	43
5. Quality assurance and Delivery guarantee for Pos-H	46
6. Application cases	47
7. Intellectual Property rights	50
[Appendix] Special Moment Frame Design	52

Pos-H

World Best H-Beam certified by POSCO

Passion, Innovation, Challenge, Future Steel Solutions POSCO and Columbus take responsibility together!

POSCO and Columbus have developed Pos-H, the world's highest quality welded H-beam, created by welding high-quality POSCO steel plates.

Pos-H consists of 953 types, the world's largest number of cross-sections, enabling efficient and optimized design that can reduce material usage by 10-30% compared to conventional H-beam designs.

The 953 types of Pos-H cross-sections have been pre-loaded into MIDAS Gen, enhancing the convenience of structural design.

Pos-H has minimized the variety of plate thicknesses and established an urgent production system, achieving a delivery time of 35 days.

Pos-H has successfully developed the world's first special moment frame for jumbo beams with a depth of 1,500mm, realizing world-class seismic performance.

Pos-H product has obtained Environmental Product Declaration (EPD) certification.

* EPD (Environmental Product Declaration)

Pos-H

- ▶ **Structure:** World-class level (Special moment realization up to 1,500mm beam depth)
- ▶ **Design:** Equipped with MIDAS Gen Program
- ▶ **Quality:** World-class level (Manufacturing tolerance)
- ▶ **Cost-effectiveness:** 10~30% material reduction compared to conventional H-beams
- ▶ **Delivery:** 35-day lead time

 **Economic efficiency**
(10~30% reduction)

 **Design convenience**
(MIDAS equipped)

 **Structure**
(world-class)

 **Quality**
(world-class)

 **Delivery time**
(35 days)

1. KS for Construction Steel Materials

Rolled steel for welded structures (KS D 3515)

Korean Standards		Yield point or Yield strength (N/mm ²)					Tensile Strength (N/mm ²)
2017 KS(new)	Conventional notation KS(old)	Thickness of steel (mm)					
		t≤16	16<t≤40	40<t≤75	75<t≤100	100<t≤200	
SM275A	SM400A	275 or more	265 or more	255 or more	245 or more	235 or more	410~550
SM275B	SM400B						
SM275C	SM400C						
SM275D	-						
SM355A	SM490A	355 or more	345 or more	335 or more	325 or more	305 or more	490~30
SM355B	SM490B						
SM355C	SM490C						
SM355D	-						
SM420A	-	420 or more	410 or more	400 or more	390 or more	380 or more	520~700
SM420B	SM520B						
SM420C	SM520C						
SM420D	-						
SM460B	SM570	460 or more	450 or more	430 or more	420 or more	-	570~720
SM460C	-						

Rolled steel for building structures (KS D 3861)

Korean Standards		Yield point or Yield strength (N/mm ²)		Tensile Strength (N/mm ²)
2017 KS(new)	Conventional notation KS(old)	Thickness of steel (mm)		
		6≤t≤40	40<t≤100	
SN275A	SN400A	275 or more	265 or more	-
SN275B	SN400B	275 to 395	255 to 375	80 or less
SN275C	SN400C	275 to 395	255 to 375	80 or less
SN355B	SN490B	355 to 475	335 to 455	80 or less
SN355C	SN490C	355 to 475	335 to 455	80 or less
SN460B	-	460 to 580	440 to 560	80 or less
SN460C	-	460 to 580	440 to 560	80 or less

Note 1 The upper limit of yield point, yield strength, or yield ratio for steel products thinner than 12 mm shall apply only if explicitly specified by the customer; otherwise, these limits do not apply..

Note 2 In the case of Thermo-Mechanical Control (TMC) rolled steel, the standard value (yield strength for 40mm or less) is applied without reduction of yield point or yield strength according to thickness.

2. Pos-H

Pos-H is a welded H-beam made using POSCO's high-quality steel plates and has the following characteristics.

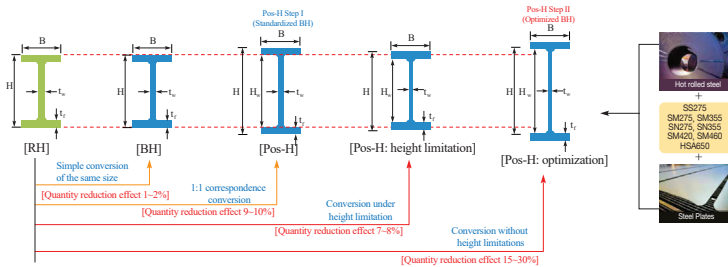





Classification		RH ¹⁾	Pos-H ²⁾	Note
Steel	Steel grade	SS, SM, SHN	SS, SM, SN	For RH, SN steel grades with better seismic performance cannot be produced.
	Production	EAF	BF	Inherent Quality Differences
Economics	No. of Sections Types	82 types	953 types	Provides greater flexibility for design optimization in a variety of structural applications.
	Material efficiency for Quantity ²⁾	1	0.8-0.9	Pos-H, more innovative than RH, reduces material
Lead Time	Lead Time	30 days	35 days	Pos-H enables fast delivery through steel plate inventory management.
Quality Assurance	Manufacturing Tolerance	Compliance with KS	Most stringent manufacturing standards	Pos-H is produced according to the world's strictest manufacturing standards.
Seismic Capacity	Connection behavior	IMF (SDR of 2%)	SMF (SDR of 4%)	Even with the same connection details, Pos-H members show far superior behavior compared to RH (certified connections are tested up to 1,500mm).
	Y.R. of Steel	less than 0.85	less than 0.8	
Weldability (Chemical Composition)	P	≤0.035	≤0.030	The lower the value, the more advantageous.
	S	≤0.030	≤0.015	
	C _{eq}	0.46	0.44/0.46	
	P _{em}	0.26	0.26/0.28	

1) The above comparison table compares RH in the SHN case and Pos-H in the SN case.

2) Steel Quantity: Pos-H is economical for beam depths over 400mm and column depths over 300mm; otherwise, review needed.

Pos-H sections comprise a total of 953 types, consisting of 734 optimized Pos-H sections and 84 standardized Pos-H sections.

Classification	Use	Shape	Quantity
Optimized Pos-H (For general design)	Flexural members	 [H shape]	734 types
		 [Asymmetric H]	20 types
	Compression members	 [H shape]	75 types
		 [Ii shape]	40 types
Sum			869 types

Classification	Use	Shape	Quantity
Standardized Pos-H	Standardization	 [H shape]	62 types
	floor height		22 types
Sum			84 types

2. Pos-H

Why is Pos-H the world's best H-beam?

Achieving the world's best seismic performance, providing the world's largest variety of cross-sections (953 types) to realize economical and quick delivery"

Seismic Performance

If you're looking for the world-class seismic steel, check the yield ratio of steel

- ▶ Pos-H, which applies SN steel, provides a world-class **yield ratio of 0.8**.



If you're seeking top-tier earthquake-resistant steel, verify the performance of the seismic connections.

- ▶ Pos-H enables world-class Special Moment Frame design for **beam depths up to 1,500mm**.

For the best earthquake-resistant steel, examine the weldability.

- ▶ Pos-H offers the highest quality welding performance through **world-class control of chemical composition**.

Excellent Quality

If you're curious about the manufacturing quality, check the manufacturing tolerance.

- ▶ Pos-H is manufactured according to the **world's strictest tolerance specifications**.



Aren't there brittle fractures in large cross-sections?

- ▶ Pos-H does not experience brittle fractures even when welded on-site during winter.

Convenience

Please check if design and VE (Value Engineering) design are supported.

- ▶ We provide free customized engineering support through Columbus.

Check the height of the beam and the width of the flange.

- ▶ The cross-section size of Pos-H changes in 50mm increments as a fixed dimension.



Does the customer have a desired cross-section?

- ▶ Pos-H can provide any cross-section the customer wants.

If you truly want a steel structure building that is safe from earthquakes, check **these 2 things** related to steel.

1. Is the material's yield ratio 0.8?

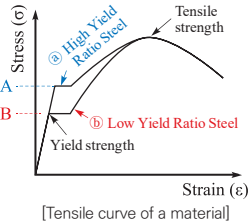
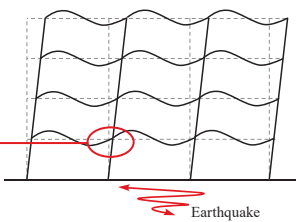

- Yield ratio = Yield strength / Tensile strength
- The lower the yield ratio, the better the material
- According to design standards, steel with a yield ratio of 0.85 or less is classified as seismic-resistant steel

Types of H-beams	General H-Beam	SHN	Pos-H
Yield ratio	-	0.85 or less	0.8 or less

- ▶ Pos-H uses materials with a yield ratio of 0.8 or less, which is world-class level

2. Is it possible to achieve the performance of a **special moment frame in jumbo beam sections**?

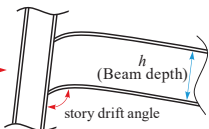

Types of H-beams	General H-Beam	SHN	Pos-H
Story drift ratio	less than 2%	2% or more	4% or more
Connection	O.M.F.	I.M.F.	S.M.F.
Range (h=beam depth)	-	h≤900mm	h≤1,500mm

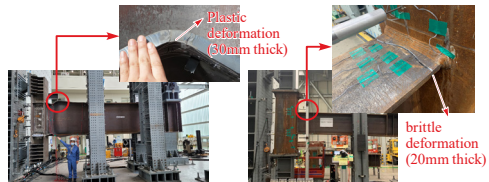

[Beam-Column Connection test applying Pos-H]
(Apply 1500mm Pos-H with 5% deformation
→ Special Moment Frame)

[Beam-Column Connection test applying SHN]
(Apply 692mm Pos-H with 2% deformation
→ Intermediate Moment Frame)

- ▶ Pos-H is the only one in the world to achieve special moment for a beam height of 1,500mm

2.1 Optimized Pos-H

The Excellence of Optimized Pos-H

POSCO World Premium H-Beam

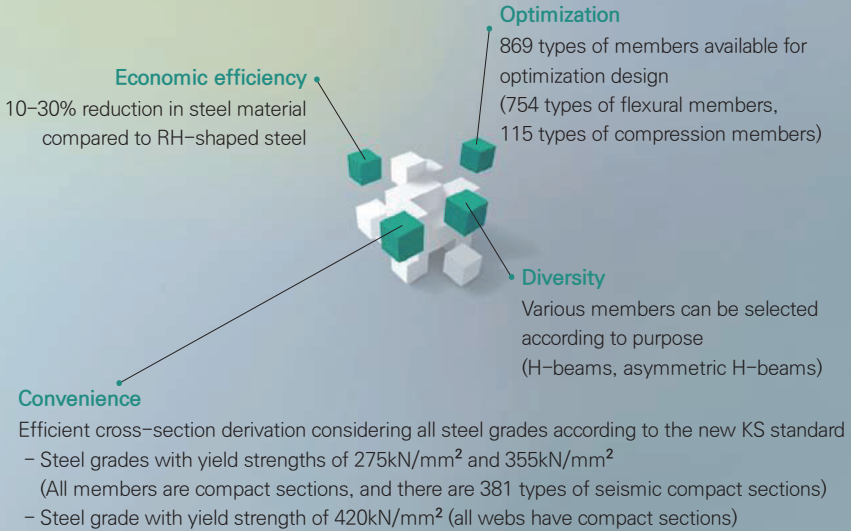

Optimized Pos-H Flexural Members

Optimized Pos-H beam flexural member production specifications

Depth (H) of Pos-H beam: Using nominal dimensions

- H: 400~1,000mm Series adjusts in 50mm increments
- 1,000~2,000mm Series adjusts in 100mm increments
- 2,000~3,000mm Series adjusts in 200mm increments

Width (B) of Pos-H beam: Use nominal dimensions

- B: Adjusted in 50mm increments in the 200~400mm Series

Web thickness (t_w)

- 8, 9, 10, 11, 12, 13, 15, 16, 17, 18, 20, 25, 30, 35mm (14 types)

Flange thickness (t_f)

- 12, 15, 18, 20, 22, 25, 28, 30, 32, 35, 40, 45, 50, 55, 60, 70, 80mm (17 types)

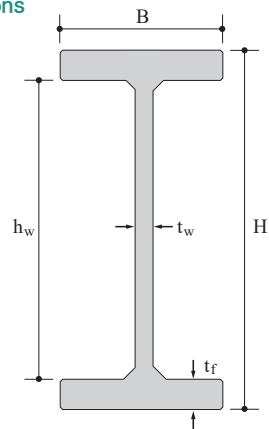

2.1 Optimized Pos-H Pos-H Member List (734 types of flexural members)

* SMF : Seismically compact sections within the certified range, applicable not only to general structures but also to O.M.F. / I.M.F. / S.M.F.

** IMF : According to AISC standards, a beam with a 10% increase in depth and a 25% increase in flange thickness can be applied up to S.M.F.

However, it is conservatively recommended to use it up to I.M.F. (Intermediate Moment Frame).

No	Section(mm)	Area	Unit weight	Moment of inertia		Radius of gyration		Elastic section modulus		Plastic section modulus		General Structure	Seismic Structure	
		A(cm ²)	(kg/m)	I _x (cm ⁴)	I _y (cm ⁴)	r _x (cm)	r _y (cm)	S _x (cm ³)	S _y (cm ³)	Z _{px} (cm ³)	Z _{py} (cm ³)		SMF*	IMF**
1	PH-HxBxt _x t _x	78.1	61.29	21,615	1,602	16.6	4.5	1,081	160	1,214	246	0	-	
2	PH-400x200x8x12	89.6	70.34	25,622	2,002	16.9	4.7	1,281	200	1,429	306	0	0	
3	PH-400x200x9x18	104.8	82.24	29,903	2,402	16.9	4.8	1,495	240	1,673	367	0	0	
4	PH-400x200x9x20	112.4	88.23	32,406	2,669	17.0	4.9	1,620	267	1,812	407	0	0	
5	PH-400x200x10x22	123.6	97.03	35,230	2,936	16.9	4.9	1,761	294	1,980	449	0	0	
6	PH-400x200x10x25	135.0	105.98	38,781	3,336	16.9	5.0	1,939	334	2,181	509	0	0	
7	PH-400x300x9x15	123.3	96.79	37,166	6,752	17.4	7.4	1,858	450	2,041	682	0	-	
8	PH-400x300x9x18	140.8	110.50	43,046	8,102	17.5	7.6	2,152	540	2,361	817	0	-	
9	PH-400x300x9x20	152.4	119.63	46,859	9,002	17.5	7.7	2,343	600	2,572	907	0	-	
10	PH-400x300x10x22	167.6	131.57	50,965	9,903	17.4	7.7	2,548	660	2,812	999	0	0	
11	PH-400x300x10x25	185.0	145.23	56,385	11,253	17.5	7.8	2,819	750	3,119	1,134	0	0	
12	PH-450x200x8x12	82.1	64.43	28,181	1,602	18.5	4.4	1,252	160	1,414	247	0	-	
13	PH-450x200x8x15	93.6	73.48	33,334	2,002	18.9	4.6	1,482	200	1,658	307	0	0	
14	PH-450x200x9x18	109.3	85.77	38,934	2,403	18.9	4.7	1,730	240	1,941	368	0	0	
15	PH-450x200x9x20	116.9	91.77	42,176	2,669	19.0	4.8	1,874	267	2,098	408	0	0	
16	PH-450x200x10x22	128.6	100.95	45,913	2,937	18.9	4.8	2,041	294	2,295	450	0	0	
17	PH-450x200x10x25	140.0	109.90	50,542	3,337	19.0	4.9	2,246	334	2,525	510	0	0	
18	PH-450x300x9x15	127.8	100.32	48,149	6,753	19.4	7.3	2,140	450	2,354	684	0	-	
19	PH-450x300x9x18	145.3	114.03	55,739	8,103	19.6	7.5	2,477	540	2,718	818	0	-	
20	PH-450x300x9x20	156.9	123.17	60,679	9,002	19.7	7.6	2,697	600	2,958	908	0	-	
21	PH-450x300x10x22	172.6	135.49	66,081	9,903	19.6	7.6	2,937	660	3,237	1,000	0	0	
22	PH-450x300x10x25	190.0	149.15	73,146	11,253	19.6	7.7	3,251	750	3,588	1,135	0	0	
23	PH-500x200x8x12	86.1	67.57	35,773	1,602	20.4	4.3	1,431	160	1,624	248	0	-	
24	PH-500x200x8x15	97.6	76.62	42,217	2,002	20.8	4.5	1,689	200	1,897	308	0	0	
25	PH-500x200x9x18	113.8	89.30	49,330	2,403	20.8	4.6	1,973	240	2,220	369	0	0	
26	PH-500x200x9x20	121.4	95.30	53,407	2,669	21.0	4.7	2,136	267	2,396	409	0	0	
27	PH-500x200x10x22	133.6	104.88	58,204	2,937	20.9	4.7	2,328	294	2,623	451	0	0	
28	PH-500x200x10x25	145.0	113.83	64,052	3,337	21.0	4.8	2,562	334	2,881	511	0	0	
29	PH-500x250x8x15	112.6	88.39	51,040	3,908	21.3	5.9	2,042	313	2,261	476	0	-	
30	PH-500x250x9x18	131.8	103.43	59,790	4,690	21.3	6.0	2,392	375	2,653	572	0	0	
31	PH-500x250x9x20	141.4	111.00	64,934	5,211	21.4	6.1	2,597	417	2,876	634	0	0	
32	PH-500x250x10x22	155.6	122.15	70,779	5,733	21.3	6.1	2,831	459	3,149	699	0	0	
33	PH-500x250x10x25	170.0	133.45	78,167	6,514	21.4	6.2	3,127	521	3,475	793	0	0	
34	PH-500x250x12x28	193.3	151.72	86,819	7,298	21.2	6.1	3,473	584	3,895	891	0	0	
35	PH-500x250x12x30	202.8	159.20	91,468	7,819	21.2	6.2	3,659	626	4,106	953	0	0	
36	PH-500x300x9x15	132.3	103.86	60,729	6,753	21.4	7.1	2,429	450	2,680	685	0	-	
37	PH-500x300x9x18	149.8	117.56	70,249	8,103	21.7	7.4	2,810	540	3,087	819	0	-	
38	PH-500x300x9x20	161.4	126.70	76,460	9,003	21.8	7.5	3,058	600	3,356	909	0	-	

2.1 Optimized Pos-H

No	Section(mm)	Area	Unit weight	Moment of inertia		Radius of gyration		Elastic section modulus		Plastic section modulus		General Structure	Seismic Structure	
	PH-HxBxt _x t _t	A(cm ²)	(kg/m)	I _x (cm ⁴)	I _y (cm ⁴)	r _x (cm)	r _y (cm)	S _x (cm ³)	S _y (cm ³)	Z _{px} (cm ³)	Z _{py} (cm ³)		SMF*	IMF**
39	PH-500x300x10x22	177.6	139.42	83,355	9,904	21.7	7.5	3,334	660	3,675	1,001	0	0	
40	PH-500x300x10x25	195.0	153.08	92,281	11,254	21.8	7.6	3,691	750	4,069	1,136	0	0	
41	PH-500x300x12x28	221.3	173.70	102,432	12,606	21.5	7.5	4,097	840	4,556	1,276	0	0	
42	PH-500x300x12x30	232.8	182.75	108,058	13,506	21.5	7.6	4,322	900	4,811	1,366	0	0	
43	PH-550x200x8x12	90.1	70.71	44,441	1,602	22.2	4.2	1,616	160	1,845	248	0	-	
44	PH-550x200x8x15	101.6	79.76	52,319	2,002	22.7	4.4	1,903	200	2,146	308	0	-	
45	PH-550x200x9x15	106.8	83.84	53,491	2,003	22.4	4.3	1,945	200	2,213	311	0	0	
46	PH-550x200x9x18	118.3	92.83	61,149	2,403	22.7	4.5	2,224	240	2,510	370	0	0	
47	PH-550x200x9x20	125.9	98.83	66,155	2,670	22.9	4.6	2,406	267	2,705	410	0	0	
48	PH-550x200x10x22	138.6	108.80	72,164	2,938	22.8	4.6	2,624	294	2,963	453	0	0	
49	PH-550x200x10x25	150.0	117.75	79,375	3,338	23.0	4.7	2,886	334	3,250	513	0	0	
50	PH-550x250x8x15	116.6	91.53	63,055	3,908	23.3	5.8	2,293	313	2,547	477	0	-	
51	PH-550x250x9x18	136.3	106.96	73,889	4,691	23.3	5.9	2,687	375	2,988	573	0	0	
52	PH-550x250x9x20	145.9	114.53	80,207	5,211	23.4	6.0	2,917	417	3,235	635	0	0	
53	PH-550x250x10x22	160.6	126.07	87,506	5,733	23.3	6.0	3,182	459	3,544	700	0	0	
54	PH-550x250x10x25	175.0	137.38	96,615	6,515	23.5	6.1	3,513	521	3,906	794	0	0	
55	PH-550x250x12x28	199.3	156.43	107,516	7,299	23.2	6.1	3,910	584	4,386	893	0	0	
56	PH-550x250x12x30	208.8	163.91	113,277	7,820	23.3	6.1	4,119	626	4,620	955	0	0	
57	PH-550x300x9x15	136.8	107.39	74,963	6,753	23.4	7.0	2,126	450	3,016	686	0	-	
58	PH-550x300x9x18	154.3	121.09	86,630	8,103	23.7	7.2	3,150	540	3,467	820	0	-	
59	PH-550x300x9x20	165.9	130.23	94,259	9,003	23.8	7.4	3,428	600	3,765	910	0	-	
60	PH-550x300x10x22	182.6	143.34	102,848	9,904	23.7	7.4	3,740	660	4,125	1,003	0	0	
61	PH-550x300x10x25	200.0	157.00	113,854	11,254	23.9	7.5	4,140	750	4,563	1,138	0	0	
62	PH-550x300x12x28	227.3	178.41	126,608	12,607	23.6	7.4	4,604	840	5,117	1,278	0	0	
63	PH-550x300x12x30	238.8	187.46	133,580	13,507	23.7	7.5	4,857	900	5,400	1,368	0	0	
64	PH-600x200x8x12	94.1	73.85	54,235	1,602	24.0	4.1	1,808	160	2,075	249	0	-	
65	PH-600x200x8x15	105.6	82.90	63,691	2,002	24.6	4.4	2,123	200	2,405	309	0	-	
66	PH-600x200x9x18	122.8	96.37	74,445	2,403	24.6	4.4	2,482	240	2,811	371	0	-	
67	PH-600x200x9x20	130.4	102.36	80,478	2,670	24.8	4.5	2,683	267	3,026	411	0	-	
68	PH-600x200x10x15	117.0	91.85	66,778	2,005	23.9	4.1	2,226	200	2,567	314	0	0	
69	PH-600x200x10x18	128.4	100.79	75,940	2,405	24.3	4.3	2,531	240	2,890	374	0	0	
70	PH-600x200x10x20	136.0	106.76	81,941	2,671	24.5	4.4	2,731	267	3,104	414	0	0	
71	PH-600x200x10x22	143.6	112.73	87,857	2,938	24.7	4.5	2,929	294	3,316	454	0	0	
72	PH-600x200x10x25	155.0	121.68	96,573	3,338	25.0	4.6	3,219	334	3,631	514	0	0	
73	PH-600x250x8x15	120.6	94.67	76,527	3,909	25.2	5.7	2,551	313	2,844	478	0	-	
74	PH-600x250x9x18	140.8	110.50	89,693	4,691	25.2	5.8	2,990	375	3,335	574	0	-	
75	PH-600x250x9x20	150.4	118.06	97,305	5,212	25.4	5.9	3,243	417	3,606	636	0	-	
76	PH-600x250x10x18	146.4	114.92	91,188	4,692	25.0	5.7	3,040	375	3,414	577	0	0	
77	PH-600x250x10x20	156.0	122.46	98,768	5,213	25.2	5.8	3,292	417	3,684	639	0	0	
78	PH-600x250x10x22	165.6	130.00	106,241	5,734	25.3	5.9	3,541	459	3,952	701	0	0	
79	PH-600x250x10x25	180.0	141.30	117,250	6,515	25.5	6.0	3,908	521	4,350	795	0	0	
80	PH-600x250x12x28	205.3	161.14	130,705	7,300	25.2	6.0	4,357	584	4,892	895	0	0	

2.1 Optimized Pos-H

No	Section(mm)	Area	Unit weight	Moment of inertia		Radius of gyration		Elastic section modulus		Plastic section modulus		General Structure	Seismic Structure	
	PH-HxBxt _x t _t	A(cm ²)	(kg/m)	I _x (cm ⁴)	I _y (cm ⁴)	r _x (cm)	r _y (cm)	S _x (cm ³)	S _y (cm ³)	Z _{px} (cm ³)	Z _{py} (cm ³)		SMF*	IMF**
81	PH-600x250x12x30	214.8	168.62	137,696	7,820	25.3	6.0	4,590	626	5,150	957	0	0	
82	PH-600x300x9x15	141.3	110.92	90,907	6,753	25.4	6.9	3,030	450	3,364	687	0	-	
83	PH-600x300x9x18	158.8	124.63	104,940	8,103	25.7	7.1	3,498	540	3,859	821	0	-	
84	PH-600x300x9x20	170.4	133.76	114,131	9,003	25.9	7.3	3,804	600	4,186	911	0	-	
85	PH-600x300x10x22	187.6	147.27	124,624	9,905	25.8	7.3	4,154	660	4,588	1,004	0	0	
86	PH-600x300x10x25	205.0	160.93	137,927	11,255	25.9	7.4	4,598	750	5,069	1,139	0	0	
87	PH-600x300x12x28	233.3	183.12	153,626	12,608	25.7	7.4	5,121	841	5,693	1,280	0	0	
88	PH-600x300x12x30	244.8	192.17	162,086	13,508	25.7	7.4	5,403	901	6,005	1,369	0	0	
89	PH-650x200x8x12	98.1	76.99	65,205	1,603	25.8	4.0	2,006	160	2,315	250	0	-	
90	PH-650x200x8x15	109.6	86.04	76,384	2,003	26.4	4.3	2,350	200	2,674	310	0	-	
91	PH-650x200x9x18	127.3	99.90	89,276	2,404	26.5	4.3	2,747	240	3,123	372	0	-	
92	PH-650x200x9x20	134.9	105.90	96,430	2,670	26.7	4.4	2,967	267	3,357	412	0	-	
93	PH-650x200x10x22	148.6	116.65	105,345	2,938	26.6	4.4	3,241	294	3,681	455	0	-	
94	PH-650x200x10x25	160.0	125.60	115,708	3,338	26.9	4.6	3,560	334	4,025	515	0	-	
95	PH-650x200x12x15	134.4	105.50	84,328	2,009	25.0	3.9	2,595	201	3,058	322	0	0	
96	PH-650x200x12x18	145.7	114.36	95,063	2,409	25.5	4.1	2,925	241	3,406	382	0	0	
97	PH-650x200x12x20	153.2	120.26	102,105	2,675	25.8	4.2	3,142	268	3,636	422	0	0	
98	PH-650x200x12x22	160.7	126.17	109,054	2,942	26.0	4.3	3,356	294	3,865	462	0	0	
99	PH-650x200x12x25	172.0	135.02	119,308	3,342	26.3	4.4	3,671	334	4,205	522	0	0	
100	PH-650x250x8x15	124.6	97.81	91,507	3,909	27.1	5.6	2,816	313	3,150	479	0	-	
101	PH-650x250x9x18	145.3	114.03	107,255	4,691	27.2	5.7	3,300	375	3,692	575	0	-	
102	PH-650x250x9x20	154.9	121.60	116,282	5,212	27.4	5.8	3,578	417	3,987	637	0	-	
103	PH-650x250x10x22	170.6	133.92	127,045	5,734	27.3	5.8	3,909	459	4,372	703	0	-	
104	PH-650x250x10x25	185.0	145.23	140,135	6,515	27.5	5.9	4,312	521	4,806	796	0	-	
105	PH-650x250x12x18	163.7	128.49	113,042	4,696	26.3	5.4	3,478	376	3,975	585	0	0	
106	PH-650x250x12x20	173.2	135.96	121,956	5,217	26.5	5.5	3,753	417	4,266	647	0	0	
107	PH-650x250x12x22	182.7	143.44	130,754	5,738	26.8	5.6	4,023	459	4,556	709	0	0	
108	PH-650x250x12x25	197.0	154.65	143,735	6,519	27.0	5.8	4,423	522	4,986	803	0	0	
109	PH-650x250x12x28	211.3	165.85	156,459	7,300	27.2	5.9	4,814	584	5,413	896	0	0	
110	PH-650x250x12x30	220.8	173.33	164,800	7,821	27.3	6.0	5,071	626	5,694	959	0	0	
111	PH-650x300x9x15	145.8	114.45	108,617	6,754	27.3	6.8	3,342	450	3,722	688	0	-	
112	PH-650x300x9x18	163.3	128.16	125,234	8,104	27.7	7.0	3,853	540	4,261	822	0	-	
113	PH-650x300x9x20	174.9	137.30	136,134	9,004	27.9	7.2	4,189	600	4,617	912	0	-	
114	PH-650x300x10x22	192.6	151.19	148,745	9,905	27.8	7.2	4,577	660	5,063	1,005	0	-	
115	PH-650x300x10x25	210.0	164.85	164,563	11,255	28.0	7.3	5,063	750	5,588	1,140	0	-	
116	PH-650x300x12x22	204.7	160.71	152,454	9,909	27.3	7.0	4,691	661	5,247	1,012	0	0	
117	PH-650x300x12x25	222.0	174.27	168,163	11,259	27.5	7.1	5,174	751	5,768	1,147	0	0	
118	PH-650x300x12x28	239.3	187.83	183,559	12,609	27.7	7.3	5,648	841	6,283	1,281	0	0	
119	PH-650x300x12x30	250.8	196.88	193,653	13,508	27.8	7.3	5,959	901	6,624	1,371	0	0	
120	PH-700x200x9x12	108.8	85.44	79,976	1,604	27.1	3.8	2,285	160	2,679	254	0	-	
121	PH-700x200x9x15	120.3	94.44	92,952	2,004	27.8	4.1	2,656	200	3,065	314	0	-	
122	PH-700x200x9x18	131.8	103.43	105,698	2,404	28.3	4.3	3,020	240	3,447	373	0	-	

2.1 Optimized Pos-H

No	Section(mm)	Area	Unit weight	Moment of inertia		Radius of gyration		Elastic section modulus		Plastic section modulus		General Structure	Seismic Structure	
		A(cm ²)	(kg/m)	I _x (cm ⁴)	I _y (cm ⁴)	r _x (cm)	r _y (cm)	S _x (cm ³)	S _y (cm ³)	Z _{px} (cm ³)	Z _{py} (cm ³)		SMF*	IMF**
123	PH-700x200x9x20	139.4	109.43	114,069	2,671	28.6	4.4	3,259	267	3,700	413	O	-	
124	PH-700x200x10x22	153.6	120.58	124,691	2,939	28.5	4.4	3,563	294	4,059	456	O	-	
125	PH-700x200x10x25	165.0	129.53	136,844	3,339	28.8	4.5	3,910	334	4,431	516	O	-	
126	PH-700x200x12x20	159.2	124.97	121,256	2,676	27.6	4.1	3,464	268	4,027	424	O	O	
127	PH-700x200x12x25	178.0	139.73	141,421	3,343	28.2	4.3	4,041	334	4,643	523	O	O	
128	PH-700x250x9x15	135.3	106.21	110,551	3,910	28.6	5.4	3,159	313	3,579	482	O	-	
129	PH-700x250x9x18	149.8	117.56	126,634	4,692	29.1	5.6	3,618	375	4,061	576	O	-	
130	PH-700x250x9x20	159.4	125.13	137,196	5,212	29.3	5.7	3,920	417	4,380	638	O	-	
131	PH-700x250x10x22	175.6	137.85	149,983	5,735	29.2	5.7	4,285	459	4,805	704	O	-	
132	PH-700x250x10x25	190.0	149.15	165,333	6,516	29.5	5.9	4,724	521	5,275	798	O	-	
133	PH-700x250x12x25	203.0	159.36	169,910	6,520	28.9	5.7	4,855	522	5,486	805	O	O	
134	PH-700x250x12x28	217.3	170.56	184,855	7,301	29.2	5.8	5,282	584	5,948	898	O	O	
135	PH-700x250x12x30	226.8	178.04	194,664	7,822	29.3	5.9	5,562	626	6,254	961	O	O	
136	PH-700x300x9x18	167.8	131.69	147,569	8,104	29.7	7.0	4,216	540	4,675	823	O	-	
137	PH-700x300x9x20	179.4	140.83	160,322	9,004	29.9	7.1	4,581	600	5,060	913	O	-	
138	PH-700x300x10x22	197.6	155.12	175,274	9,905	29.8	7.1	5,008	660	5,551	1,006	O	-	
139	PH-700x300x10x25	215.0	168.78	193,823	11,255	30.0	7.2	5,538	750	6,119	1,141	O	-	
140	PH-700x300x12x22	210.7	165.42	179,979	9,909	29.2	6.9	5,142	661	5,766	1,014	O	O	
141	PH-700x300x12x25	228.0	178.98	198,400	11,259	29.5	7.0	5,669	751	6,330	1,148	O	O	
142	PH-700x300x12x28	245.3	192.54	216,484	12,609	29.7	7.2	6,185	841	6,889	1,283	O	O	
143	PH-700x300x12x30	256.8	201.59	228,354	13,509	29.8	7.3	6,524	901	7,259	1,373	O	O	
144	PH-700x300x12x32	268.3	210.63	240,077	14,409	29.9	7.3	6,859	961	7,626	1,463	O	O	
145	PH-700x300x16x35	310.8	243.98	265,722	15,772	29.2	7.1	7,592	1,051	8,570	1,615	O	O	
146	PH-700x300x16x40	339.2	266.27	293,457	18,021	29.4	7.3	8,384	1,201	9,458	1,840	O	O	
147	PH-700x350x9x18	185.8	145.82	168,505	12,867	30.1	8.3	4,814	735	5,289	1,116	O	-	
148	PH-700x350x9x20	199.4	156.53	183,449	14,296	30.3	8.5	5,241	817	5,740	1,238	O	-	
149	PH-700x350x10x22	219.6	172.39	200,565	15,726	30.2	8.5	5,730	899	6,296	1,364	O	-	
150	PH-700x350x10x25	240.0	188.40	222,313	17,870	30.4	8.6	6,352	1,021	6,963	1,548	O	-	
151	PH-700x350x12x25	253.0	198.61	226,890	17,874	29.9	8.4	6,483	1,021	7,174	1,555	O	O	
152	PH-700x350x12x28	273.3	214.52	248,113	20,018	30.1	8.6	7,089	1,144	7,830	1,738	O	O	
153	PH-700x350x12x30	286.8	225.14	262,044	21,447	30.2	8.6	7,487	1,226	8,264	1,861	O	O	
154	PH-700x350x12x32	300.3	235.75	275,803	22,876	30.3	8.7	7,880	1,307	8,695	1,983	O	O	
155	PH-700x350x16x35	345.8	271.45	304,453	25,032	29.7	8.5	8,699	1,430	9,734	2,184	O	O	
156	PH-700x350x16x40	379.2	297.67	337,070	28,604	29.8	8.7	9,631	1,635	10,778	2,490	O	O	
157	PH-750x250x9x15	139.8	109.74	129,300	3,911	30.4	5.3	3,448	313	3,923	483	O	-	
158	PH-750x250x9x18	154.3	121.09	147,884	4,692	31.0	5.5	3,944	375	4,441	577	O	-	
159	PH-750x250x9x20	163.9	128.66	160,102	5,213	31.3	5.6	4,269	417	4,784	639	O	-	
160	PH-750x250x10x22	180.6	141.77	175,115	5,735	31.1	5.6	4,670	459	5,250	705	O	-	
161	PH-750x250x10x25	195.0	153.08	192,906	6,516	31.5	5.8	5,144	521	5,756	799	O	-	
162	PH-750x250x12x22	194.7	152.86	180,980	5,739	30.5	5.4	4,826	459	5,499	713	O	O	
163	PH-750x250x12x25	209.0	164.07	198,623	6,520	30.8	5.6	5,297	522	6,001	806	O	O	
164	PH-750x250x12x28	223.3	175.27	215,966	7,302	31.1	5.7	5,759	584	6,499	900	O	O	

2.1 Optimized Pos-H

No	Section(mm)	Area	Unit weight	Moment of inertia		Radius of gyration		Elastic section modulus		Plastic section modulus		General Structure	Seismic Structure	
	PH-HxBxt _x t _t	A(cm ²)	(kg/m)	I _x (cm ⁴)	I _y (cm ⁴)	r _x (cm)	r _y (cm)	S _x (cm ³)	S _y (cm ³)	Z _{px} (cm ³)	Z _{py} (cm ³)		SMF*	IMF**
165	PH-750x250x12x30	232.8	182.75	227,363	7,822	31.3	5.8	6,063	626	6,828	962	O	O	
166	PH-750x300x9x18	172.3	135.22	172,001	8,104	31.6	6.9	4,587	540	5,100	824	O	-	
167	PH-750x300x9x20	183.9	144.36	186,753	9,004	31.9	7.0	4,980	600	5,514	914	O	-	
168	PH-750x300x10x22	202.6	159.04	204,273	9,906	31.8	7.0	5,447	660	6,051	1,008	O	-	
169	PH-750x300x10x25	220.0	172.70	225,771	11,256	32.0	7.2	6,021	750	6,663	1,143	O	-	
170	PH-750x300x12x22	216.7	170.13	210,138	9,910	31.1	6.8	5,604	661	6,300	1,015	O	O	
171	PH-750x300x12x25	234.0	183.69	231,488	11,260	31.5	6.9	6,173	751	6,908	1,150	O	O	
172	PH-750x300x12x28	251.3	197.25	252,475	12,610	31.7	7.1	6,733	841	7,510	1,285	O	O	
173	PH-750x300x12x30	262.8	206.30	266,266	13,510	31.8	7.2	7,100	901	7,908	1,375	O	O	
174	PH-750x300x12x32	274.3	215.34	279,898	14,410	31.9	7.2	7,464	961	8,305	1,465	O	O	
175	PH-750x300x16x35	318.8	250.26	310,532	15,773	31.2	7.0	8,281	1,052	9,357	1,619	O	O	
176	PH-750x300x16x40	347.2	272.55	342,882	18,023	31.4	7.2	9,144	1,202	10,316	1,843	O	O	
177	PH-750x350x9x18	190.3	149.35	196,118	12,867	32.1	8.2	5,230	735	5,759	1,117	O	-	
178	PH-750x350x10x20	211.0	165.64	216,388	14,298	32.0	8.2	5,770	817	6,370	1,243	O	-	
179	PH-750x350x10x22	224.6	176.31	233,431	15,727	32.2	8.4	6,225	899	6,852	1,365	O	-	
180	PH-750x350x10x25	245.0	192.33	258,635	17,870	32.5	8.5	6,897	1,021	7,569	1,549	O	-	
181	PH-750x350x12x25	259.0	203.32	264,352	17,875	31.9	8.3	7,049	1,021	7,814	1,556	O	O	
182	PH-750x350x12x28	279.3	219.23	288,983	20,018	32.2	8.5	7,706	1,144	8,521	1,740	O	O	
183	PH-750x350x12x30	292.8	229.85	305,168	21,447	32.3	8.6	8,138	1,226	8,988	1,862	O	O	
184	PH-750x350x12x32	306.3	240.46	321,167	22,877	32.4	8.6	8,564	1,307	9,453	1,985	O	O	
185	PH-750x350x16x35	353.8	277.73	355,300	25,034	31.7	8.4	9,475	1,430	10,608	2,187	O	O	
186	PH-750x350x16x40	387.2	303.95	393,345	28,606	31.9	8.6	10,489	1,635	11,736	2,493	O	O	
187	PH-800x250x10x15	152.0	119.32	153,601	3,913	31.8	5.1	3,840	313	4,426	488	O	-	
188	PH-800x250x10x18	166.4	130.62	174,779	4,694	32.4	5.3	4,369	376	4,978	582	O	-	
189	PH-800x250x10x20	176.0	138.16	188,715	5,215	32.7	5.4	4,718	417	5,344	644	O	-	
190	PH-800x250x10x22	185.6	145.70	202,504	5,735	33.0	5.6	5,063	459	5,708	706	O	-	
191	PH-800x250x10x25	200.0	157.00	222,917	6,517	33.4	5.7	5,573	521	6,250	800	O	-	
192	PH-800x250x12x28	229.3	179.98	249,869	7,302	33.0	5.6	6,247	584	7,065	902	O	-	
193	PH-800x250x12x30	238.8	187.46	262,972	7,823	33.2	5.7	6,574	626	7,418	964	O	-	
194	PH-800x250x16x22	231.0	181.30	224,108	5,755	31.2	5.0	5,603	460	6,565	736	O	O	
195	PH-800x250x16x25	245.0	192.33	244,010	6,536	31.6	5.2	6,100	523	7,094	829	O	O	
196	PH-800x250x16x28	259.0	203.35	263,597	7,317	31.9	5.3	6,590	585	7,618	923	O	O	
197	PH-800x250x16x30	268.4	210.69	276,480	7,838	32.1	5.4	6,912	627	7,965	985	O	O	
198	PH-800x300x10x18	184.4	144.75	202,303	8,106	33.1	6.6	5,058	540	5,682	829	O	-	
199	PH-800x300x10x20	196.0	153.86	219,141	9,006	33.4	6.8	5,479	600	6,124	919	O	-	
200	PH-800x300x10x22	207.6	162.97	235,804	9,906	33.7	6.9	5,895	660	6,564	1,009	O	-	
201	PH-800x300x10x25	225.0	176.63	260,469	11,256	34.0	7.1	6,512	750	7,219	1,144	O	-	
202	PH-800x300x12x28	257.3	201.96	291,606	12,611	33.7	7.0	7,290	841	8,145	1,287	O	-	
203	PH-800x300x12x30	268.8	211.01	307,462	13,511	33.8	7.1	7,687	901	8,573	1,377	O	-	
204	PH-800x300x12x32	280.3	220.05	323,148	14,411	34.0	7.2	8,079	961	8,998	1,466	O	-	
205	PH-800x300x16x22	253.0	198.57	257,408	9,926	31.9	6.3	6,435	662	7,421	1,038	O	O	
206	PH-800x300x16x25	270.0	211.95	281,563	11,276	32.3	6.5	7,039	752	8,063	1,173	O	O	

2.1 Optimized Pos-H

No	Section(mm)	Area	Unit weight	Moment of inertia		Radius of gyration		Elastic section modulus		Plastic section modulus		General Structure	Seismic Structure	
	PH-HxBxt _x t _t	A(cm ²)	(kg/m)	I _x (cm ⁴)	I _y (cm ⁴)	r _x (cm)	r _y (cm)	S _x (cm ³)	S _y (cm ³)	Z _{px} (cm ³)	Z _{py} (cm ³)		SMF*	IMF**
207	PH-800x300x16x28	287.0	225.33	305,334	12,625	32.6	6.6	7,633	842	8,699	1,308	0	0	
208	PH-800x300x16x30	298.4	234.24	320,970	13,525	32.8	6.7	8,024	902	9,120	1,397	0	0	
209	PH-800x300x16x35	326.8	256.54	359,326	15,775	33.2	6.9	8,983	1,052	10,164	1,622	0	0	
210	PH-800x300x16x40	355.2	278.83	396,646	18,025	33.4	7.1	9,916	1,202	11,194	1,846	0	0	
211	PH-800x350x10x20	216.0	169.56	249,568	14,298	34.0	8.1	6,239	817	6,904	1,244	0	-	
212	PH-800x350x12x22	244.7	192.11	276,305	15,732	33.6	8.0	6,908	899	7,705	1,375	0	-	
213	PH-800x350x12x25	265.0	208.03	305,052	17,875	33.9	8.2	7,626	1,021	8,469	1,558	0	-	
214	PH-800x350x12x28	285.3	223.94	333,343	20,019	34.2	8.4	8,334	1,144	9,226	1,742	0	-	
215	PH-800x350x12x30	298.8	234.56	351,952	21,448	34.3	8.5	8,799	1,226	9,728	1,864	0	-	
216	PH-800x350x12x32	312.3	245.17	370,361	22,877	34.4	8.6	9,259	1,307	10,227	1,986	0	-	
217	PH-800x350x16x25	295.0	231.58	319,115	17,890	32.9	7.8	7,978	1,022	9,031	1,579	0	0	
218	PH-800x350x16x28	315.0	247.31	347,071	20,034	33.2	8.0	8,677	1,145	9,780	1,763	0	0	
219	PH-800x350x16x30	328.4	257.79	365,460	21,463	33.4	8.1	9,136	1,226	10,275	1,885	0	0	
220	PH-800x350x16x35	361.8	284.01	410,569	25,035	33.7	8.3	10,264	1,431	11,503	2,190	0	0	
221	PH-800x350x16x40	395.2	310.23	454,460	28,608	33.9	8.5	11,361	1,635	12,714	2,496	0	0	
222	PH-800x400x12x22	266.7	209.38	309,604	23,478	34.1	9.4	7,740	1,174	8,561	1,787	0	-	
223	PH-800x400x12x25	290.0	227.65	342,604	26,677	34.4	9.6	8,565	1,334	9,438	2,027	0	-	
224	PH-800x400x12x28	313.3	245.92	375,080	29,877	34.6	9.8	9,377	1,494	10,307	2,267	0	-	
225	PH-800x400x12x30	328.8	258.11	396,442	32,011	34.7	9.9	9,911	1,601	10,883	2,427	0	-	
226	PH-800x400x12x32	344.3	270.29	417,575	34,144	34.8	10.0	10,439	1,707	11,455	2,586	0	-	
227	PH-800x400x16x28	343.0	269.29	388,808	29,892	33.7	9.3	9,720	1,495	10,861	2,288	0	0	
228	PH-800x400x16x30	358.4	281.34	409,950	32,025	33.8	9.5	10,249	1,601	11,430	2,447	0	0	
229	PH-800x400x16x35	396.8	311.49	461,812	37,358	34.1	9.7	11,545	1,868	12,842	2,847	0	0	
230	PH-800x400x16x40	435.2	341.63	512,273	42,691	34.3	9.9	12,807	2,135	14,234	3,246	0	0	
231	PH-850x250x10x15	157.0	123.25	176,691	3,913	33.5	5.0	4,157	313	4,812	489	0	-	
232	PH-850x250x10x18	171.4	134.55	200,721	4,694	34.2	5.2	4,723	376	5,400	583	0	-	
233	PH-850x250x10x20	181.0	142.09	216,545	5,215	34.6	5.4	5,095	417	5,790	645	0	-	
234	PH-850x250x12x22	206.7	162.28	240,941	5,741	34.1	5.3	5,669	459	6,503	717	0	-	
235	PH-850x250x12x25	221.0	173.49	263,960	6,522	34.6	5.4	6,211	522	7,076	810	0	-	
236	PH-850x250x12x28	235.3	184.69	286,637	7,303	34.9	5.6	6,744	584	7,645	904	0	-	
237	PH-850x250x12x30	244.8	192.17	301,566	7,824	35.1	5.7	7,096	626	8,022	966	0	-	
238	PH-850x250x16x22	239.0	187.58	258,394	5,757	32.9	4.9	6,080	461	7,153	739	0	0	
239	PH-850x250x16x25	253.0	198.61	281,027	6,538	33.3	5.1	6,612	523	7,716	832	0	0	
240	PH-850x250x16x28	267.0	209.63	303,323	7,319	33.7	5.2	7,137	586	8,276	926	0	0	
241	PH-850x250x16x30	276.4	216.97	318,001	7,839	33.9	5.3	7,482	627	8,646	988	0	0	
242	PH-850x300x10x18	189.4	148.68	231,876	8,107	35.0	6.5	5,456	540	6,149	830	0	-	
243	PH-850x300x10x20	201.0	157.79	250,997	9,007	35.3	6.7	5,906	600	6,620	920	0	-	
244	PH-850x300x12x22	228.7	179.55	278,657	9,912	34.9	6.6	6,557	661	7,414	1,019	0	-	
245	PH-850x300x12x25	246.0	193.11	306,513	11,262	35.3	6.8	7,212	751	8,108	1,154	0	-	
246	PH-850x300x12x28	263.3	206.67	333,954	12,611	35.6	6.9	7,858	841	8,796	1,289	0	-	
247	PH-850x300x12x30	274.8	215.72	352,019	13,511	35.8	7.0	8,283	901	9,252	1,378	0	-	
248	PH-850x300x12x32	286.3	224.76	369,902	14,411	35.9	7.1	8,704	961	9,706	1,468	0	-	

2.1 Optimized Pos-H

No	Section(mm)	Area	Unit weight	Moment of inertia		Radius of gyration		Elastic section modulus		Plastic section modulus		General Structure	Seismic Structure	
	PH-HxBxt _x t _x	A(cm ²)	(kg/m)	I _x (cm ⁴)	I _y (cm ⁴)	r _x (cm)	r _y (cm)	S _x (cm ³)	S _y (cm ³)	Z _{px} (cm ³)	Z _{py} (cm ³)		SMF*	IMF**
249	PH-850x300x16x22	261.0	204.85	296,110	9,928	33.7	6.2	6,967	662	8,063	1,042	0	0	
250	PH-850x300x16x25	278.0	218.23	323,579	11,277	34.1	6.4	7,614	752	8,748	1,176	0	0	
251	PH-850x300x16x28	295.0	231.61	350,639	12,627	34.5	6.5	8,250	842	9,427	1,311	0	0	
252	PH-850x300x16x30	306.4	240.52	368,454	13,527	34.7	6.6	8,669	902	9,876	1,401	0	0	
253	PH-850x300x16x35	334.8	262.82	412,206	15,777	35.1	6.9	9,699	1,052	10,991	1,625	0	0	
254	PH-850x300x16x40	363.2	285.11	454,851	18,026	35.4	7.0	10,702	1,202	12,092	1,849	0	0	
255	PH-850x350x12x20	237.2	186.20	294,306	14,303	35.2	7.8	6,925	817	7,778	1,254	0	-	
256	PH-850x350x12x22	250.7	196.82	316,373	15,732	35.5	7.9	7,444	899	8,325	1,377	0	-	
257	PH-850x350x12x25	271.0	212.74	349,065	17,876	35.9	8.1	8,213	1,021	9,139	1,560	0	-	
258	PH-850x350x12x28	291.3	228.65	381,270	20,020	36.2	8.3	8,971	1,144	9,947	1,744	0	-	
259	PH-850x350x12x30	304.8	239.27	402,471	21,449	36.3	8.4	9,470	1,226	10,482	1,866	0	-	
260	PH-850x350x12x32	318.3	249.88	423,459	22,878	36.5	8.5	9,964	1,307	11,015	1,988	0	-	
261	PH-850x350x16x25	303.0	237.86	366,131	17,892	34.8	7.7	8,615	1,022	9,779	1,582	0	0	
262	PH-850x350x16x28	323.0	253.59	397,955	20,035	35.1	7.9	9,364	1,145	10,577	1,766	0	0	
263	PH-850x350x16x30	336.4	264.07	418,906	21,464	35.3	8.0	9,857	1,227	11,106	1,888	0	0	
264	PH-850x350x16x35	369.8	290.29	470,362	25,037	35.7	8.2	11,067	1,431	12,417	2,194	0	0	
265	PH-850x350x16x40	403.2	316.51	520,514	28,610	35.9	8.4	12,247	1,635	13,712	2,499	0	0	
266	PH-850x400x12x22	272.7	214.09	354,089	23,478	36.0	9.3	8,331	1,174	9,235	1,789	0	-	
267	PH-850x400x12x25	296.0	232.36	391,617	26,678	36.4	9.5	9,215	1,334	10,170	2,029	0	-	
268	PH-850x400x12x28	319.3	250.63	428,586	29,878	36.6	9.7	10,084	1,494	11,098	2,269	0	-	
269	PH-850x400x12x30	334.8	262.82	452,924	32,011	36.8	9.8	10,657	1,601	11,712	2,428	0	-	
270	PH-850x400x12x32	350.3	275.00	477,017	34,145	36.9	9.9	11,224	1,707	12,324	2,588	0	-	
271	PH-850x400x16x28	351.0	275.57	445,272	29,894	35.6	9.2	10,477	1,495	11,728	2,291	0	0	
272	PH-850x400x16x30	366.4	287.62	469,359	32,027	35.8	9.3	11,044	1,601	12,336	2,451	0	0	
273	PH-850x400x16x35	404.8	317.77	528,517	37,360	36.1	9.6	12,436	1,868	13,844	2,850	0	0	
274	PH-850x400x16x40	443.2	347.91	586,178	42,693	36.4	9.8	13,792	2,135	15,332	3,249	0	0	
275	PH-900x250x12x20	203.2	159.51	257,239	5,221	35.6	5.1	5,716	418	6,619	656	0	-	
276	PH-900x250x12x22	212.7	166.99	274,760	5,741	35.9	5.2	6,106	459	7,027	718	0	-	
277	PH-900x250x12x25	227.0	178.20	300,735	6,523	36.4	5.4	6,683	522	7,636	812	0	-	
278	PH-900x250x12x28	241.3	189.40	326,347	7,304	36.8	5.5	7,252	584	8,241	905	0	-	
279	PH-900x250x12x30	250.8	196.88	343,220	7,825	37.0	5.6	7,627	626	8,642	968	0	-	
280	PH-900x250x16x22	247.0	193.86	295,667	5,758	34.6	4.8	6,570	461	7,760	742	0	0	
281	PH-900x250x16x25	261.0	204.89	321,206	6,539	35.1	5.0	7,138	523	8,359	836	0	0	
282	PH-900x250x16x28	275.0	215.91	346,387	7,320	35.5	5.2	7,697	586	8,953	929	0	0	
283	PH-900x250x16x30	284.4	223.25	362,977	7,841	35.7	5.3	8,066	627	9,347	991	0	0	
284	PH-900x300x12x20	223.2	175.21	295,966	9,012	36.4	6.4	6,577	601	7,499	931	0	-	
285	PH-900x300x12x22	234.7	184.26	317,167	9,912	36.8	6.5	7,048	661	7,993	1,021	0	-	
286	PH-900x300x12x25	252.0	197.82	348,600	11,262	37.2	6.7	7,747	751	8,730	1,156	0	-	
287	PH-900x300x12x28	269.3	211.38	379,592	12,612	37.5	6.8	8,435	841	9,462	1,290	0	-	
288	PH-900x300x12x30	280.8	220.43	400,010	13,512	37.7	6.9	8,889	901	9,947	1,380	0	-	
289	PH-900x300x12x32	292.3	229.47	420,235	14,412	37.9	7.0	9,339	961	10,429	1,470	0	-	
290	PH-900x300x16x22	269.0	211.13	338,075	9,929	35.5	6.1	7,513	662	8,726	1,045	0	0	

2.1 Optimized Pos-H

No	Section(mm)	Area	Unit weight	Moment of inertia		Radius of gyration		Elastic section modulus		Plastic section modulus		General Structure	Seismic Structure	
	PH-HxBxt _x t _t	A(cm ²)	(kg/m)	I _x (cm ⁴)	I _y (cm ⁴)	r _x (cm)	r _y (cm)	S _x (cm ³)	S _y (cm ³)	Z _{px} (cm ³)	Z _{py} (cm ³)		SMF*	IMF**
291	PH-900x300x16x25	286.0	224.51	369,071	11,279	35.9	6.3	8,202	752	9,453	1,179	0	0	
292	PH-900x300x16x28	303.0	237.89	399,633	12,629	36.3	6.5	8,881	842	10,174	1,314	0	0	
293	PH-900x300x16x30	314.4	246.80	419,767	13,529	36.5	6.6	9,328	902	10,652	1,404	0	0	
294	PH-900x300x16x35	342.8	269.10	469,271	15,778	37.0	6.8	10,428	1,052	11,838	1,628	0	0	
295	PH-900x300x16x40	371.2	291.39	517,596	18,028	37.3	7.0	11,502	1,202	13,010	1,852	0	0	
296	PH-900x300x20x50	460.0	361.10	627,833	22,553	36.9	7.0	13,952	1,504	15,950	2,330	0	0	
297	PH-900x300x20x60	516.0	405.06	715,212	27,052	37.2	7.2	15,894	1,803	18,162	2,778	0	0	
298	PH-900x350x12x20	243.2	190.91	334,692	14,304	37.1	7.7	7,438	817	8,379	1,256	0	-	
299	PH-900x350x12x22	256.7	201.53	359,575	15,733	37.4	7.8	7,991	899	8,959	1,378	0	-	
300	PH-900x350x12x25	277.0	217.45	396,465	17,877	37.8	8.0	8,810	1,022	9,824	1,562	0	-	
301	PH-900x350x16x25	311.0	244.14	416,935	17,894	36.6	7.6	9,265	1,022	10,546	1,586	0	0	
302	PH-900x350x16x28	331.0	259.87	452,878	20,037	37.0	7.8	10,064	1,145	11,395	1,769	0	0	
303	PH-900x350x16x30	344.4	270.35	476,557	21,466	37.2	7.9	10,590	1,227	11,957	1,891	0	0	
304	PH-900x350x16x32	357.8	280.84	500,012	22,895	37.4	8.0	11,111	1,308	12,517	2,014	0	0	
305	PH-900x350x16x35	377.8	296.57	534,776	25,039	37.6	8.1	11,884	1,431	13,352	2,197	0	0	
306	PH-900x350x16x40	411.2	322.79	591,609	28,611	37.9	8.3	13,147	1,635	14,730	2,502	0	0	
307	PH-900x350x20x50	510.0	400.35	718,250	35,783	37.5	8.4	15,961	2,045	18,075	3,143	0	0	
308	PH-900x350x20x60	576.0	452.16	821,232	42,927	37.8	8.6	18,250	2,453	20,682	3,753	0	0	
309	PH-900x400x12x22	278.7	218.80	401,982	23,479	38.0	9.2	8,933	1,174	9,925	1,791	0	-	
310	PH-900x400x16x25	336.0	263.76	464,800	26,696	37.2	8.9	10,329	1,335	11,640	2,054	0	-	
311	PH-900x400x16x28	359.0	281.85	506,123	29,895	37.5	9.1	11,247	1,495	12,616	2,294	0	0	
312	PH-900x400x16x30	374.4	293.90	533,347	32,029	37.7	9.2	11,852	1,601	13,262	2,454	0	0	
313	PH-900x400x16x32	389.8	305.96	560,313	34,162	37.9	9.4	12,451	1,708	13,906	2,614	0	0	
314	PH-900x400x16x35	412.8	324.05	600,282	37,362	38.1	9.5	13,340	1,868	14,866	2,853	0	0	
315	PH-900x400x16x40	451.2	354.19	665,622	42,695	38.4	9.7	14,792	2,135	16,450	3,252	0	0	
316	PH-900x400x20x45	522.0	409.77	747,104	48,054	37.8	9.6	16,602	2,403	18,671	3,681	0	0	
317	PH-900x400x20x50	560.0	439.60	808,667	53,387	38.0	9.8	17,970	2,669	20,200	4,080	0	0	
318	PH-900x400x20x55	598.0	469.43	868,710	58,719	38.1	9.9	19,305	2,936	21,711	4,479	0	0	
319	PH-900x400x20x60	636.0	499.26	927,252	64,052	38.2	10.0	20,606	3,203	23,202	4,878	0	0	
320	PH-950x250x12x20	209.2	164.22	291,615	5,221	37.3	5.0	6,139	418	7,134	658	0	-	
321	PH-950x250x12x22	218.7	171.70	311,238	5,742	37.7	5.1	6,552	459	7,567	720	0	-	
322	PH-950x250x12x25	233.0	182.91	340,348	6,523	38.2	5.3	7,165	522	8,211	814	0	-	
323	PH-950x250x12x28	247.3	194.11	369,073	7,305	38.6	5.4	7,770	584	8,852	907	0	-	
324	PH-950x250x12x30	256.8	201.59	388,009	7,825	38.9	5.5	8,169	626	9,276	970	0	-	
325	PH-950x250x16x22	255.0	200.14	336,027	5,760	36.3	4.8	7,074	461	8,387	745	0	0	
326	PH-950x250x16x25	269.0	211.17	364,648	6,541	36.8	4.9	7,677	523	9,021	839	0	0	
327	PH-950x250x16x28	283.0	222.19	392,890	7,322	37.3	5.1	8,271	586	9,651	932	0	0	
328	PH-950x250x16x30	292.4	229.53	411,508	7,843	37.5	5.2	8,663	627	10,068	994	0	0	
329	PH-950x300x12x20	229.2	179.92	334,867	9,013	38.2	6.3	7,050	601	8,064	933	0	-	
330	PH-950x300x12x22	240.7	188.97	358,612	9,913	38.6	6.4	7,550	661	8,587	1,023	0	-	
331	PH-950x300x12x25	258.0	202.53	393,838	11,263	39.1	6.6	8,291	751	9,368	1,157	0	-	
332	PH-950x300x12x28	275.3	216.09	428,597	12,613	39.5	6.8	9,023	841	10,143	1,292	0	-	

2.1 Optimized Pos-H

No	Section(mm)	Area A(cm ²)	Unit weight (kg/m)	Moment of inertia		Radius of gyration		Elastic section modulus		Plastic section modulus		General Struc- ture	Seismic Structure	
				I _x (cm ⁴)	I _y (cm ⁴)	r _x (cm)	r _y (cm)	S _x (cm ³)	S _y (cm ³)	Z _{px} (cm ³)	Z _{py} (cm ³)		SMF*	IMF**
333	PH-950x300x12x30	286.8	225.14	451,512	13,513	39.7	6.9	9,506	901	10,656	1,382	O	-	
334	PH-950x300x12x32	298.3	234.18	474,222	14,413	39.9	7.0	9,984	961	11,168	1,472	O	-	
335	PH-950x300x16x22	277.0	217.41	383,401	9,931	37.2	6.0	8,072	662	9,408	1,048	O	O	
336	PH-950x300x16x25	294.0	230.79	418,138	11,281	37.7	6.2	8,803	752	10,178	1,183	O	O	
337	PH-950x300x16x28	311.0	244.17	452,414	12,631	38.1	6.4	9,525	842	10,942	1,317	O	O	
338	PH-950x300x16x30	322.4	253.08	475,011	13,530	38.4	6.5	10,000	902	11,448	1,407	O	O	
339	PH-950x300x16x35	350.8	275.38	530,620	15,780	38.9	6.7	11,171	1,052	12,705	1,631	O	O	
340	PH-950x300x16x40	379.2	297.67	584,980	18,030	39.3	6.9	12,315	1,202	13,948	1,856	O	O	
341	PH-950x300x20x45	442.0	346.97	659,307	20,307	38.6	6.8	13,880	1,354	15,916	2,111	O	O	
342	PH-950x300x20x50	470.0	368.95	710,479	22,557	38.9	6.9	14,957	1,504	17,113	2,335	O	O	
343	PH-950x300x20x55	498.0	390.93	760,462	24,806	39.1	7.1	16,010	1,654	18,296	2,559	O	O	
344	PH-950x300x20x60	526.0	412.91	809,268	27,055	39.2	7.2	17,037	1,804	19,465	2,783	O	O	
345	PH-950x350x12x20	249.2	195.62	378,119	14,305	39.0	7.6	7,960	817	8,994	1,258	O	-	
346	PH-950x350x12x22	262.7	206.24	405,986	15,734	39.3	7.7	8,547	899	9,608	1,380	O	-	
347	PH-950x350x12x25	283.0	222.16	447,327	17,878	39.8	7.9	9,417	1,022	10,524	1,564	O	-	
348	PH-950x350x16x25	319.0	250.42	471,627	17,895	38.5	7.5	9,929	1,023	11,334	1,589	O	O	
349	PH-950x350x16x28	339.0	266.15	511,938	20,039	38.9	7.7	10,778	1,145	12,233	1,772	O	O	
350	PH-950x350x16x30	352.4	276.63	538,513	21,468	39.1	7.8	11,337	1,227	12,828	1,894	O	O	
351	PH-950x350x16x32	365.8	287.12	564,851	22,897	39.3	7.9	11,892	1,308	13,422	2,010	O	O	
352	PH-950x350x16x35	385.8	302.85	603,913	25,040	39.6	8.1	12,714	1,431	14,306	2,207	O	O	
353	PH-950x350x16x40	419.2	329.07	667,844	28,613	39.9	8.3	14,060	1,635	15,768	2,506	O	O	
354	PH-950x350x20x45	487.0	382.30	751,523	32,214	39.3	8.1	15,822	1,841	17,952	2,842	O	O	
355	PH-950x350x20x50	520.0	408.20	811,833	35,786	39.5	8.3	17,091	2,045	19,363	3,148	O	O	
356	PH-950x350x20x55	553.0	434.11	870,741	39,358	39.7	8.4	18,331	2,249	20,757	3,453	O	O	
357	PH-950x350x20x60	586.0	460.01	928,263	42,930	39.8	8.6	19,542	2,453	22,135	3,758	O	O	
358	PH-950x400x12x22	284.7	223.51	453,360	23,480	39.9	9.1	9,544	1,174	10,629	1,793	O	-	
359	PH-950x400x16x25	344.0	270.04	525,117	26,697	39.1	8.8	11,055	1,335	12,490	2,058	O	-	
360	PH-950x400x16x28	367.0	288.13	571,462	29,897	39.5	9.0	12,031	1,495	13,523	2,297	O	O	
361	PH-950x400x16x30	382.4	300.18	602,016	32,030	39.7	9.2	12,674	1,602	14,208	2,457	O	O	
362	PH-950x400x16x35	420.8	330.33	677,206	37,363	40.1	9.4	14,257	1,868	15,908	2,856	O	O	
363	PH-950x400x16x40	459.2	360.47	750,707	42,696	40.4	9.6	15,804	2,135	17,588	3,256	O	O	
364	PH-950x400x20x45	532.0	417.62	843,739	48,057	39.8	9.5	17,763	2,403	19,988	3,686	O	O	
365	PH-950x400x20x50	570.0	447.45	913,188	53,390	40.0	9.7	19,225	2,670	21,613	4,085	O	O	
366	PH-950x400x20x55	608.0	477.28	981,021	58,723	40.2	9.8	20,653	2,936	23,218	4,484	O	O	O
367	PH-950x400x20x60	646.0	507.11	1,047,258	64,055	40.3	10.0	22,048	3,203	24,805	4,883	O	O	
368	PH-1000x300x12x20	235.2	184.63	376,634	9,014	40.0	6.2	7,533	601	8,645	935	O	-	
369	PH-1000x300x12x22	246.7	193.68	403,065	9,914	40.4	6.3	8,061	661	9,197	1,024	O	-	
370	PH-1000x300x12x25	264.0	207.24	442,300	11,264	40.9	6.5	8,846	751	10,020	1,159	O	-	
371	PH-1000x300x16x28	319.0	250.45	509,083	12,632	39.9	6.3	10,182	842	11,729	1,320	O	-	
372	PH-1000x300x16x30	330.4	259.36	534,285	13,532	40.2	6.4	10,686	902	12,264	1,410	O	O	
373	PH-1000x300x16x35	358.8	281.66	596,355	15,782	40.8	6.6	11,927	1,052	13,592	1,635	O	O	
374	PH-1000x300x16x40	387.2	303.95	657,105	18,031	41.2	6.8	13,142	1,202	14,906	1,859	O	O	

2.1 Optimized Pos-H

No	Section(mm)	Area	Unit weight	Moment of inertia		Radius of gyration		Elastic section modulus		Plastic section modulus		General Structure	Seismic Structure	
	PH-HxBxt _x t _t	A(cm ²)	(kg/m)	I _x (cm ⁴)	I _y (cm ⁴)	r _x (cm)	r _y (cm)	S _x (cm ³)	S _y (cm ³)	Z _{px} (cm ³)	Z _{py} (cm ³)		SMF*	IMF**
375	PH-1000x300x18x22	304.1	238.70	446,751	9,946	38.3	5.7	8,935	663	10,568	1,067	0	0	
376	PH-1000x300x18x25	321.0	251.99	485,169	11,296	38.9	5.9	9,703	753	11,374	1,202	0	0	
377	PH-1000x300x18x28	337.9	265.27	523,104	12,646	39.3	6.1	10,462	843	12,175	1,336	0	0	
378	PH-1000x300x20x45	452.0	354.82	741,668	20,311	40.5	6.7	14,833	1,354	17,033	2,116	0	0	
379	PH-1000x300x20x50	480.0	376.80	799,000	22,560	40.8	6.9	15,980	1,504	18,300	2,340	0	0	
380	PH-1000x300x20x55	508.0	398.78	855,072	24,809	41.0	7.0	17,101	1,654	19,553	2,564	0	0	
381	PH-1000x300x20x60	536.0	420.76	909,899	27,059	41.2	7.1	18,198	1,804	20,792	2,788	0	0	
382	PH-1000x350x16x22	307.0	240.96	484,805	15,753	39.7	7.2	9,696	900	11,186	1,409	0	-	
383	PH-1000x350x16x25	327.0	256.70	530,306	17,897	40.3	7.4	10,606	1,023	12,141	1,592	0	-	
384	PH-1000x350x16x28	347.0	272.43	575,237	20,041	40.7	7.6	11,505	1,145	13,090	1,775	0	-	
385	PH-1000x350x16x30	360.4	282.91	604,875	21,470	41.0	7.7	12,097	1,227	13,719	1,898	0	0	
386	PH-1000x350x16x35	393.8	309.13	677,873	25,042	41.5	8.0	13,557	1,431	15,281	2,203	0	0	
387	PH-1000x350x16x40	427.2	335.35	749,318	28,615	41.9	8.2	14,986	1,635	16,826	2,509	0	0	
388	PH-1000x350x18x25	346.0	271.61	544,596	17,911	39.7	7.2	10,892	1,023	12,593	1,608	0	0	
389	PH-1000x350x18x28	365.9	287.25	589,257	20,054	40.1	7.4	11,785	1,146	13,536	1,791	0	0	
390	PH-1000x350x20x45	497.0	390.15	844,346	32,217	41.2	8.1	16,887	1,841	19,182	2,847	0	0	
391	PH-1000x350x20x50	530.0	416.05	911,917	35,789	41.5	8.2	18,238	2,045	20,675	3,153	0	0	
392	PH-1000x350x20x55	563.0	441.96	978,002	39,361	41.7	8.4	19,560	2,249	22,152	3,458	0	0	
393	PH-1000x350x20x60	596.0	467.86	1,042,619	42,934	41.8	8.5	20,852	2,453	23,612	3,763	0	0	
394	PH-1000x400x16x25	352.0	276.32	589,733	26,699	40.9	8.7	11,795	1,335	13,360	2,061	0	-	
395	PH-1000x400x16x28	375.0	294.41	641,390	29,899	41.4	8.9	12,828	1,495	14,451	2,300	0	-	
396	PH-1000x400x16x30	390.4	306.46	675,465	32,032	41.6	9.1	13,509	1,602	15,174	2,460	0	0	
397	PH-1000x400x16x35	428.8	336.61	759,391	37,365	42.1	9.3	15,188	1,868	16,970	2,860	0	0	
398	PH-1000x400x16x40	467.2	366.75	841,532	42,698	42.4	9.6	16,831	2,135	18,746	3,259	0	0	
399	PH-1000x400x18x28	393.9	309.23	655,410	29,913	40.8	8.7	13,108	1,496	14,897	2,316	0	0	
400	PH-1000x400x20x45	542.0	425.47	947,025	48,061	41.8	9.4	18,941	2,403	21,331	3,691	0	0	
401	PH-1000x400x20x50	580.0	455.30	1,024,833	53,393	42.0	9.6	20,497	2,670	23,050	4,090	0	0	
402	PH-1000x400x20x55	618.0	485.13	1,100,932	58,726	42.2	9.7	22,019	2,936	24,751	4,489	0	0	
403	PH-1000x400x20x60	656.0	514.96	1,175,339	64,059	42.3	9.9	23,507	3,203	26,432	4,888	0	0	0
404	PH-1100x300x16x25	318.0	249.63	587,788	11,286	43.0	6.0	10,687	752	12,473	1,192	0	-	
405	PH-1100x300x16x30	346.4	271.92	665,322	13,535	43.8	6.3	12,097	902	13,956	1,417	0	-	
406	PH-1100x300x16x35	374.8	294.22	741,379	15,785	44.5	6.5	13,480	1,052	15,426	1,641	0	-	
407	PH-1100x300x16x40	403.2	316.51	815,974	18,035	45.0	6.7	14,836	1,202	16,882	1,865	0	-	
408	PH-1100x300x18x22	322.1	252.83	560,179	9,951	41.7	5.6	10,185	663	12,133	1,076	0	0	
409	PH-1100x300x18x25	339.0	266.12	607,081	11,301	42.3	5.8	11,038	753	13,024	1,210	0	0	
410	PH-1100x300x18x28	355.9	279.40	653,451	12,651	42.8	6.0	11,881	843	13,910	1,345	0	0	
411	PH-1100x300x18x30	367.2	288.25	684,070	13,551	43.2	6.1	12,438	903	14,497	1,434	0	0	
412	PH-1100x300x18x35	395.4	310.39	759,592	15,800	43.8	6.3	13,811	1,053	15,957	1,658	0	0	
413	PH-1100x300x18x40	423.6	332.53	833,661	18,050	44.4	6.5	15,157	1,203	17,402	1,883	0	0	
414	PH-1100x300x20x45	472.0	370.52	923,464	20,317	44.2	6.6	16,790	1,354	19,343	2,126	0	0	
415	PH-1100x300x20x50	500.0	392.50	994,167	22,567	44.6	6.7	18,076	1,504	20,750	2,350	0	0	
416	PH-1100x300x20x55	528.0	414.48	1,063,469	24,816	44.9	6.9	19,336	1,654	22,143	2,574	0	0	

2.1 Optimized Pos-H

No	Section(mm)	Area	Unit weight	Moment of inertia		Radius of gyration		Elastic section modulus		Plastic section modulus		General Structure	Seismic Structure	
	PH-HxBxt _x t _t	A(cm ²)	(kg/m)	I _x (cm ⁴)	I _y (cm ⁴)	r _x (cm)	r _y (cm)	S _x (cm ³)	S _y (cm ³)	Z _{px} (cm ³)	Z _{py} (cm ³)		SMF*	IMF**
417	PH-1100x300x20x60	556.0	436.46	1,131,385	27,065	45.1	7.0	20,571	1,804	23,522	2,798	0	0	
418	PH-1100x350x18x25	364.0	285.74	679,321	17,916	43.2	7.0	12,351	1,024	14,368	1,616	0	0	
419	PH-1100x350x18x28	383.9	301.38	733,912	20,059	43.7	7.2	13,344	1,146	15,410	1,800	0	0	
420	PH-1100x350x18x30	397.2	311.80	769,960	21,488	44.0	7.4	13,999	1,228	16,102	1,922	0	0	
421	PH-1100x350x18x35	430.4	337.86	858,872	25,060	44.7	7.6	15,616	1,432	17,820	2,227	0	0	
422	PH-1100x350x18x40	463.6	363.93	946,075	28,633	45.2	7.9	17,201	1,636	19,522	2,533	0	0	
423	PH-1100x350x20x50	550.0	431.75	1,132,083	35,796	45.4	8.1	20,583	2,045	23,375	3,163	0	0	
424	PH-1100x350x20x60	616.0	483.56	1,293,805	42,940	45.8	8.3	23,524	2,454	26,642	3,773	0	0	
425	PH-1100x400x16x25	368.0	288.88	732,267	26,703	44.6	8.5	13,314	1,335	15,160	2,067	0	-	
426	PH-1100x400x16x30	406.4	319.02	837,102	32,035	45.4	8.9	15,220	1,602	17,166	2,467	0	-	
427	PH-1100x400x16x35	444.8	349.17	939,940	37,368	46.0	9.2	17,090	1,868	19,154	2,866	0	-	
428	PH-1100x400x16x40	483.2	379.31	1,040,801	42,701	46.4	9.4	18,924	2,135	21,122	3,265	0	-	
429	PH-1100x400x18x28	411.9	323.36	814,373	29,917	44.5	8.5	14,807	1,496	16,911	2,325	0	0	
430	PH-1100x400x18x30	427.2	335.35	855,850	32,051	44.8	8.7	15,561	1,603	17,707	2,484	0	0	
431	PH-1100x400x18x35	465.4	365.34	958,152	37,383	45.4	9.0	17,421	1,869	19,684	2,883	0	0	
432	PH-1100x400x18x40	503.6	395.33	1,058,488	42,716	45.8	9.2	19,245	2,136	21,642	3,283	0	0	
433	PH-1100x400x20x45	562.0	441.17	1,174,047	48,067	45.7	9.2	21,346	2,403	24,091	3,701	0	0	
434	PH-1100x400x20x50	600.0	471.00	1,270,000	53,400	46.0	9.4	23,091	2,670	26,000	4,100	0	0	
435	PH-1100x400x20x55	638.0	500.83	1,364,053	58,733	46.2	9.6	24,801	2,937	27,891	4,499	0	0	
436	PH-1100x400x20x60	676.0	530.66	1,456,225	64,065	46.4	9.7	26,477	3,203	29,762	4,898	0	0	0
437	PH-1200x300x16x25	334.0	262.19	720,596	11,289	46.4	5.8	12,010	753	14,103	1,199	0	-	
438	PH-1200x300x16x30	362.4	284.48	813,679	13,539	47.4	6.1	13,561	903	15,728	1,423	0	-	
439	PH-1200x300x16x35	390.8	306.78	905,144	15,789	48.1	6.4	15,086	1,053	17,340	1,647	0	-	
440	PH-1200x300x16x40	419.2	329.07	995,004	18,038	48.7	6.6	16,583	1,203	18,938	1,872	0	-	
441	PH-1200x300x20x22	363.2	285.11	715,456	9,977	44.4	5.2	11,924	665	14,456	1,106	0	0	
442	PH-1200x300x20x25	380.0	298.30	771,292	11,327	45.1	5.5	12,855	755	15,425	1,240	0	0	
443	PH-1200x300x20x28	396.8	311.49	826,547	12,676	45.6	5.7	13,776	845	16,388	1,374	0	0	
444	PH-1200x300x20x30	408.0	320.28	863,064	13,576	46.0	5.8	14,384	905	17,028	1,464	0	0	
445	PH-1200x300x20x35	436.0	342.26	953,240	15,825	46.8	6.0	15,887	1,055	18,617	1,688	0	0	
446	PH-1200x300x20x40	464.0	364.24	1,041,835	18,075	47.4	6.2	17,364	1,205	20,192	1,912	0	0	
447	PH-1200x300x20x45	492.0	386.22	1,128,861	20,324	47.9	6.4	18,814	1,355	21,753	2,136	0	0	
448	PH-1200x300x20x50	520.0	408.20	1,214,333	22,573	48.3	6.6	20,239	1,505	23,300	2,360	0	0	
449	PH-1200x300x20x55	548.0	430.18	1,298,266	24,823	48.7	6.7	21,638	1,655	24,833	2,584	0	0	
450	PH-1200x300x20x60	576.0	452.16	1,380,672	27,072	49.0	6.9	23,011	1,805	26,352	2,808	0	0	
451	PH-1200x350x20x25	405.0	317.93	857,594	17,941	46.0	6.7	14,293	1,025	16,894	1,646	0	0	
452	PH-1200x350x20x28	424.8	333.47	922,717	20,085	46.6	6.9	15,379	1,148	18,029	1,829	0	0	
453	PH-1200x350x20x30	438.0	343.83	965,754	21,514	47.0	7.0	16,096	1,229	18,783	1,952	0	0	
454	PH-1200x350x20x35	471.0	369.74	1,072,033	25,086	47.7	7.3	17,867	1,433	20,656	2,257	0	0	
455	PH-1200x350x20x40	504.0	395.64	1,176,448	28,658	48.3	7.5	19,607	1,638	22,512	2,562	0	0	
456	PH-1200x350x20x50	570.0	447.45	1,379,750	35,803	49.2	7.9	22,996	2,046	26,175	3,173	0	0	
457	PH-1200x350x20x60	636.0	499.26	1,575,792	42,947	49.8	8.2	26,263	2,454	29,772	3,783	0	0	
458	PH-1200x400x16x25	384.0	301.44	893,200	26,706	48.2	8.3	14,887	1,335	17,040	2,074	0	-	

2.1 Optimized Pos-H

No	Section(mm)	Area	Unit weight	Moment of inertia		Radius of gyration		Elastic section modulus		Plastic section modulus		General Structure	Seismic Structure	
		A(cm ²)	(kg/m)	I _x (cm ⁴)	I _y (cm ⁴)	r _x (cm)	r _y (cm)	S _x (cm ³)	S _y (cm ³)	Z _{px} (cm ³)	Z _{py} (cm ³)		SMF*	IMF**
459	PH-1200x400x16x30	422.4	331.58	1,019,059	32,039	49.1	8.7	16,984	1,602	19,238	2,473	0	-	
460	PH-1200x400x16x35	460.8	361.73	1,142,730	37,372	49.8	9.0	19,045	1,869	21,418	2,872	0	-	
461	PH-1200x400x16x40	499.2	391.87	1,264,230	42,705	50.3	9.2	21,071	2,135	23,578	3,272	0	-	
462	PH-1200x400x20x28	452.8	355.45	1,018,886	29,943	47.4	8.1	16,981	1,497	19,670	2,354	0	0	
463	PH-1200x400x20x30	468.0	367.38	1,068,444	32,076	47.8	8.3	17,807	1,604	20,538	2,514	0	0	
464	PH-1200x400x20x35	506.0	397.21	1,190,826	37,409	48.5	8.6	19,847	1,870	22,695	2,913	0	0	
465	PH-1200x400x20x40	544.0	427.04	1,311,061	42,741	49.1	8.9	21,851	2,137	24,832	3,312	0	0	
466	PH-1200x400x20x45	582.0	456.87	1,429,169	48,074	49.6	9.1	23,819	2,404	26,951	3,711	0	0	
467	PH-1200x400x20x50	620.0	486.70	1,545,167	53,407	49.9	9.3	25,753	2,670	29,050	4,110	0	0	
468	PH-1200x400x20x55	658.0	516.53	1,659,075	58,739	50.2	9.4	27,651	2,937	31,131	4,509	0	0	
469	PH-1200x400x20x60	696.0	546.36	1,770,912	64,072	50.4	9.6	29,515	3,204	33,192	4,908	0	0	0
470	PH-1300x300x20x30	428.0	335.98	1,043,711	13,583	49.4	5.6	16,057	906	19,118	1,474	0	-	
471	PH-1300x300x20x35	456.0	357.96	1,150,477	15,832	50.2	5.9	17,700	1,055	20,847	1,698	0	-	
472	PH-1300x300x20x40	484.0	379.94	1,255,521	18,081	50.9	6.1	19,316	1,205	22,562	1,922	0	-	
473	PH-1300x300x20x45	512.0	401.92	1,358,858	20,331	51.5	6.3	20,906	1,355	24,263	2,146	0	-	
474	PH-1300x300x20x50	540.0	423.90	1,460,500	22,580	52.0	6.5	22,469	1,505	25,950	2,370	0	-	
475	PH-1300x300x20x55	568.0	445.88	1,560,462	24,829	52.4	6.6	24,007	1,655	27,623	2,594	0	-	
476	PH-1300x300x20x60	596.0	467.86	1,658,759	27,079	52.8	6.7	25,519	1,805	29,282	2,818	0	-	
477	PH-1300x300x22x22	408.3	320.53	902,291	10,011	47.0	5.0	13,881	667	17,111	1,142	0	0	
478	PH-1300x300x22x25	425.0	333.63	967,760	11,361	47.7	5.2	14,889	757	18,156	1,276	0	0	
479	PH-1300x300x22x28	441.7	346.72	1,032,604	12,710	48.4	5.4	15,886	847	19,196	1,411	0	0	
480	PH-1300x300x22x30	452.8	355.45	1,075,488	13,610	48.7	5.5	16,546	907	19,887	1,500	0	0	
481	PH-1300x300x22x35	480.6	377.27	1,181,491	15,859	49.6	5.7	18,177	1,057	21,603	1,724	0	0	
482	PH-1300x300x22x40	508.4	399.09	1,285,785	18,108	50.3	6.0	19,781	1,207	23,306	1,948	0	0	
483	PH-1300x300x22x50	564.0	442.74	1,489,300	22,606	51.4	6.3	22,912	1,507	26,670	2,395	0	0	
484	PH-1300x300x22x60	619.6	486.39	1,686,143	27,105	52.2	6.6	25,941	1,807	29,978	2,843	0	0	
485	PH-1300x300x25x70	710.0	557.35	1,915,447	31,651	51.9	6.7	29,468	2,110	34,240	3,331	0	0	0
486	PH-1300x350x22x25	450.0	353.25	1,069,375	17,976	48.7	6.3	16,452	1,027	19,750	1,683	0	0	
487	PH-1300x350x22x28	469.7	368.70	1,145,882	20,119	49.4	6.5	17,629	1,150	20,977	1,866	0	0	
488	PH-1300x350x22x30	482.8	379.00	1,196,478	21,548	49.8	6.7	18,407	1,231	21,792	1,988	0	0	
489	PH-1300x350x22x35	515.6	404.75	1,321,547	25,120	50.6	7.0	20,331	1,435	23,817	2,293	0	0	
490	PH-1300x350x22x40	548.4	430.49	1,444,599	28,692	51.3	7.2	22,225	1,640	25,826	2,598	0	0	
491	PH-1300x350x22x50	614.0	481.99	1,684,717	35,836	52.4	7.6	25,919	2,048	29,795	3,208	0	0	
492	PH-1300x350x22x60	679.6	533.49	1,916,963	42,980	53.1	8.0	29,492	2,456	33,698	3,818	0	0	0
493	PH-1300x350x25x70	780.0	612.30	2,180,490	50,172	52.9	8.0	33,546	2,867	38,545	4,469	0	0	0
494	PH-1300x400x20x30	488.0	383.08	1,285,691	32,083	51.3	8.1	19,780	1,604	22,928	2,524	0	-	
495	PH-1300x400x20x35	526.0	412.91	1,430,588	37,415	52.2	8.4	22,009	1,871	25,275	2,923	0	-	
496	PH-1300x400x20x40	564.0	442.74	1,573,148	42,748	52.8	8.7	24,202	2,137	27,602	3,322	0	-	
497	PH-1300x400x20x45	602.0	472.57	1,713,390	48,081	53.3	8.9	26,360	2,404	29,611	3,721	0	-	
498	PH-1300x400x20x50	640.0	502.40	1,851,333	53,413	53.8	9.1	28,482	2,671	32,200	4,120	0	-	
499	PH-1300x400x20x55	678.0	532.23	1,986,997	58,746	54.1	9.3	30,569	2,937	34,471	4,519	0	-	
500	PH-1300x400x20x60	716.0	562.06	2,120,399	64,079	54.4	9.5	32,622	3,204	36,722	4,918	0	-	

2.1 Optimized Pos-H

No	Section(mm)	Area	Unit weight	Moment of inertia		Radius of gyration		Elastic section modulus		Plastic section modulus		General Structure	Seismic Structure	
	PH-HxBxt _x t _y	A(cm ²)	(kg/m)	I _x (cm ⁴)	I _y (cm ⁴)	r _x (cm)	r _y (cm)	S _x (cm ³)	S _y (cm ³)	Z _{px} (cm ³)	Z _{py} (cm ³)		SMF*	IMF**
501	PH-1300x400x22x28	497.7	390.68	1,259,159	29,977	50.3	7.8	19,372	1,499	22,758	2,391	0	0	
502	PH-1300x400x22x30	512.8	402.55	1,317,468	32,110	50.7	7.9	20,269	1,606	23,697	2,550	0	0	
503	PH-1300x400x22x35	550.6	432.22	1,461,602	37,442	51.5	8.2	22,486	1,872	26,031	2,949	0	0	
504	PH-1300x400x22x40	588.4	461.89	1,603,412	42,775	52.2	8.5	24,668	2,139	28,346	3,348	0	0	
505	PH-1300x400x22x50	664.0	521.24	1,880,133	53,440	53.2	9.0	28,925	2,672	32,920	4,145	0	0	0
506	PH-1300x400x22x60	739.6	580.59	2,147,783	64,105	53.9	9.3	33,043	3,205	37,418	4,943	0	0	0
507	PH-1300x400x25x70	850.0	667.25	2,445,533	74,818	53.6	9.4	37,624	3,741	42,850	5,781	0	-	
508	PH-1400x300x20x30	448.0	351.68	1,245,757	13,589	52.7	5.5	17,797	906	21,308	1,484	0	-	
509	PH-1400x300x20x35	476.0	373.66	1,370,514	15,839	53.7	5.8	19,579	1,056	23,177	1,708	0	-	
510	PH-1400x300x20x40	504.0	395.64	1,493,408	18,088	54.4	6.0	21,334	1,206	25,032	1,932	0	-	
511	PH-1400x300x20x45	532.0	417.62	1,614,454	20,337	55.1	6.2	23,064	1,356	26,873	2,156	0	-	
512	PH-1400x300x20x50	560.0	439.60	1,733,667	22,587	55.6	6.4	24,767	1,506	28,700	2,380	0	-	
513	PH-1400x300x20x55	588.0	461.58	1,851,059	24,836	56.1	6.5	26,444	1,656	30,513	2,604	0	-	
514	PH-1400x300x20x60	616.0	483.56	1,966,645	27,085	56.5	6.6	28,095	1,806	32,312	2,828	0	-	
515	PH-1400x300x25x25	487.5	382.69	1,221,641	11,426	50.1	4.8	17,452	762	21,703	1,336	0	0	
516	PH-1400x300x25x28	504.0	395.64	1,296,485	12,775	50.7	5.0	18,521	852	22,814	1,470	0	0	
517	PH-1400x300x25x30	515.0	404.28	1,346,012	13,674	51.1	5.2	19,229	912	23,553	1,559	0	0	
518	PH-1400x300x25x35	542.5	425.86	1,468,540	15,923	52.0	5.4	20,979	1,062	25,388	1,783	0	0	
519	PH-1400x300x25x40	570.0	447.45	1,589,240	18,172	52.8	5.6	22,703	1,211	27,210	2,006	0	0	
520	PH-1400x300x25x50	625.0	490.63	1,825,208	22,669	54.0	6.0	26,074	1,511	30,813	2,453	0	0	
521	PH-1400x300x25x60	680.0	533.80	2,054,027	27,167	55.0	6.3	29,343	1,811	34,360	2,900	0	0	0
522	PH-1400x300x25x70	735.0	576.98	2,275,805	31,664	55.6	6.6	32,512	2,111	37,853	3,347	0	0	0
523	PH-1400x350x25x25	512.5	402.31	1,339,818	18,040	51.1	5.9	19,140	1,031	23,422	1,742	0	0	
524	PH-1400x350x25x28	532.0	417.62	1,428,270	20,183	51.8	6.2	20,404	1,153	24,735	1,925	0	0	
525	PH-1400x350x25x30	545.0	427.83	1,486,802	21,612	52.2	6.3	21,240	1,235	25,608	2,047	0	0	
526	PH-1400x350x25x35	577.5	453.34	1,631,608	25,184	53.2	6.6	23,309	1,439	27,777	2,352	0	0	
527	PH-1400x350x25x40	610.0	478.85	1,774,253	28,755	53.9	6.9	25,346	1,643	29,930	2,656	0	0	
528	PH-1400x350x25x50	675.0	529.88	2,053,125	35,898	55.2	7.3	29,330	2,051	34,188	3,266	0	0	0
529	PH-1400x350x25x60	740.0	580.90	2,323,547	43,042	56.0	7.6	33,194	2,460	38,380	3,875	0	0	0
530	PH-1400x400x20x30	508.0	398.78	1,527,337	32,089	54.8	7.9	21,819	1,604	25,418	2,534	0	-	
531	PH-1400x400x20x35	546.0	428.61	1,696,650	37,422	55.7	8.3	24,238	1,871	27,955	2,933	0	-	
532	PH-1400x400x20x40	584.0	458.44	1,863,435	42,755	56.5	8.6	26,620	2,138	30,472	3,332	0	-	
533	PH-1400x400x20x45	622.0	488.27	2,027,712	48,087	57.1	8.8	28,967	2,404	32,971	3,731	0	-	
534	PH-1400x400x20x50	660.0	518.10	2,189,500	53,420	57.6	9.0	31,279	2,671	35,450	4,130	0	-	
535	PH-1400x400x20x55	698.0	547.93	2,348,818	58,753	58.0	9.2	33,555	2,938	37,911	4,529	0	-	
536	PH-1400x400x20x60	736.0	577.76	2,505,685	64,085	58.3	9.3	35,796	3,204	40,352	4,928	0	-	
537	PH-1400x400x25x28	560.0	439.60	1,560,055	30,042	52.8	7.3	22,287	1,502	26,656	2,450	0	0	
538	PH-1400x400x25x30	575.0	451.38	1,627,592	32,174	53.2	7.5	23,251	1,609	27,663	2,609	0	0	
539	PH-1400x400x25x35	612.5	480.81	1,794,676	37,507	54.1	7.8	25,638	1,875	30,166	3,008	0	0	
540	PH-1400x400x25x40	650.0	510.25	1,959,267	42,839	54.9	8.1	27,990	2,142	32,650	3,406	0	0	0
541	PH-1400x400x25x50	725.0	569.13	2,281,042	53,503	56.1	8.6	32,586	2,675	37,563	4,203	0	0	0
542	PH-1400x400x25x70	875.0	686.88	2,895,492	74,831	57.5	9.2	41,364	3,742	47,163	5,797	0	-	

2.1 Optimized Pos-H

No	Section(mm)	Area	Unit weight	Moment of inertia		Radius of gyration		Elastic section modulus		Plastic section modulus		General Structure	Seismic Structure	
	PH-HxBxt _x t _y	A(cm ²)	(kg/m)	I _x (cm ⁴)	I _y (cm ⁴)	r _x (cm)	r _y (cm)	S _x (cm ³)	S _y (cm ³)	Z _{px} (cm ³)	Z _{py} (cm ³)		SMF*	IMF**
543	PH-1500x300x20x30	468.0	367.38	1,470,204	13,596	56.0	5.4	19,603	906	23,598	1,494	O	-	
544	PH-1500x300x20x35	496.0	389.36	1,614,350	15,845	57.1	5.7	21,525	1,056	25,607	1,718	O	-	
545	PH-1500x300x20x40	524.0	411.34	1,756,495	18,095	57.9	5.9	23,420	1,206	27,602	1,942	O	-	
546	PH-1500x300x20x45	552.0	433.32	1,896,651	20,344	58.6	6.1	25,289	1,356	29,583	2,166	O	-	
547	PH-1500x300x20x50	580.0	455.30	2,034,833	22,593	59.2	6.2	27,131	1,506	31,550	2,390	O	-	
548	PH-1500x300x20x55	608.0	477.28	2,171,056	24,843	59.8	6.4	28,947	1,656	33,503	2,614	O	-	
549	PH-1500x300x20x60	636.0	499.26	2,305,332	27,092	60.2	6.5	30,738	1,806	35,442	2,838	O	-	
550	PH-1500x300x25x25	512.5	402.31	1,451,068	11,439	53.2	4.7	19,348	763	24,203	1,352	O	O	
551	PH-1500x300x25x28	529.0	415.27	1,537,437	12,788	53.9	4.9	20,499	853	25,397	1,486	O	O	
552	PH-1500x300x25x30	540.0	423.90	1,594,620	13,688	54.3	5.0	21,262	913	26,190	1,575	O	O	
553	PH-1500x300x25x35	567.5	445.49	1,736,192	15,936	55.3	5.3	23,149	1,062	28,163	1,798	O	O	
554	PH-1500x300x25x40	595.0	467.08	1,875,798	18,185	56.1	5.5	25,011	1,212	30,123	2,022	O	O	
555	PH-1500x300x25x50	650.0	510.25	2,149,167	22,682	57.5	5.9	28,656	1,512	34,000	2,469	O	O	O
556	PH-1500x300x25x60	705.0	553.43	2,414,835	27,180	58.5	6.2	32,198	1,812	37,823	2,916	O	O	O
557	PH-1500x300x25x70	760.0	596.60	2,672,913	31,677	59.3	6.5	35,639	2,112	41,590	3,363	O	O	O
558	PH-1500x350x25x25	537.5	421.94	1,587,057	18,053	54.3	5.8	21,161	1,032	26,047	1,758	O	O	
559	PH-1500x350x25x28	557.0	437.25	1,689,131	20,196	55.1	6.0	22,522	1,154	27,458	1,941	O	O	
560	PH-1500x350x25x30	570.0	447.45	1,756,710	21,625	55.5	6.2	23,423	1,236	28,395	2,063	O	O	
561	PH-1500x350x25x35	602.5	472.96	1,924,023	25,197	56.5	6.5	25,654	1,440	30,727	2,367	O	O	
562	PH-1500x350x25x40	635.0	498.48	2,089,012	28,768	57.4	6.7	27,853	1,644	33,043	2,672	O	O	
563	PH-1500x350x25x50	700.0	549.50	2,412,083	35,911	58.7	7.2	32,161	2,052	37,625	3,281	O	O	O
564	PH-1500x350x25x60	765.0	600.53	2,726,055	43,055	59.7	7.5	36,347	2,460	42,143	3,891	O	O	O
565	PH-1500x400x20x30	528.0	414.48	1,794,384	32,096	58.3	7.8	23,925	1,605	28,008	2,544	O	-	
566	PH-1500x400x20x35	566.0	444.31	1,990,011	37,429	59.3	8.1	26,533	1,871	30,735	2,943	O	-	
567	PH-1500x400x20x40	604.0	474.14	2,182,921	42,761	60.1	8.4	29,106	2,138	33,442	3,342	O	-	
568	PH-1500x400x20x45	642.0	503.97	2,373,134	48,094	60.8	8.7	31,642	2,405	36,131	3,741	O	-	
569	PH-1500x400x20x50	680.0	533.80	2,560,667	53,427	61.4	8.9	34,142	2,671	38,800	4,140	O	-	
570	PH-1500x400x20x55	718.0	563.63	2,745,540	58,759	61.8	9.0	36,607	2,938	41,451	4,539	O	-	
571	PH-1500x400x20x60	756.0	593.46	2,927,772	64,092	62.2	9.2	39,037	3,205	44,082	4,938	O	-	
572	PH-1500x400x25x28	585.0	459.23	1,840,824	30,055	56.1	7.2	24,544	1,503	29,519	2,466	O	O	
573	PH-1500x400x25x30	600.0	471.00	1,918,800	32,188	56.6	7.3	25,584	1,609	30,600	2,625	O	O	
574	PH-1500x400x25x35	637.5	500.44	2,111,853	37,520	57.6	7.7	28,158	1,876	33,291	3,023	O	O	
575	PH-1500x400x25x40	675.0	529.88	2,302,225	42,852	58.4	8.0	30,696	2,143	35,963	3,422	O	O	O
576	PH-1500x400x25x50	750.0	588.75	2,675,000	53,516	59.7	8.4	35,667	2,676	41,250	4,219	O	O	O
577	PH-1500x400x25x70	900.0	706.50	3,389,200	74,844	61.4	9.1	45,189	3,742	51,600	5,813	O	-	
578	PH-1600x300x20x30	488.0	383.08	1,718,051	13,603	59.3	5.3	21,476	907	25,988	1,504	O	-	
579	PH-1600x300x20x40	544.0	427.04	2,045,781	18,101	61.3	5.8	25,572	1,207	30,272	1,952	O	-	
580	PH-1600x300x20x50	600.0	471.00	2,365,000	22,600	62.8	6.1	29,563	1,507	34,500	2,400	O	-	
581	PH-1600x300x25x60	730.0	573.05	2,810,893	27,193	62.1	6.1	35,136	1,813	41,410	2,931	O	-	
582	PH-1600x300x25x70	785.0	616.23	3,108,022	31,690	62.9	6.4	38,850	2,113	45,453	3,378	O	O	
583	PH-1600x300x28x28	600.3	471.25	1,896,860	12,882	56.2	4.6	23,711	859	29,892	1,563	O	O	
584	PH-1600x300x28x30	611.2	479.79	1,961,535	13,782	56.7	4.7	24,519	919	30,731	1,652	O	O	

2.1 Optimized Pos-H

No	Section(mm)	Area	Unit weight	Moment of inertia		Radius of gyration		Elastic section modulus		Plastic section modulus		General Structure	Seismic Structure	
	PH-HxBxt _x t _t	A(cm ²)	(kg/m)	I _x (cm ⁴)	I _y (cm ⁴)	r _x (cm)	r _y (cm)	S _x (cm ³)	S _y (cm ³)	Z _{px} (cm ³)	Z _{py} (cm ³)		SMF*	IMF**
585	PH-1600x300x28x35	638.4	501.14	2,121,759	16,030	57.7	5.0	26,522	1,069	32,819	1,875	0	0	
586	PH-1600x300x28x40	665.6	522.50	2,279,902	18,278	58.5	5.2	28,499	1,219	34,893	2,098	0	0	0
587	PH-1600x300x28x50	720.0	565.20	2,590,000	22,774	60.0	5.6	32,375	1,518	39,000	2,544	0	0	0
588	PH-1600x300x28x60	774.4	607.90	2,891,938	27,271	61.1	5.9	36,149	1,818	43,053	2,990	0	0	0
589	PH-1600x350x28x28	628.3	493.23	2,069,861	20,291	57.4	5.7	25,873	1,159	32,093	2,018	0	0	
590	PH-1600x350x28x30	641.2	503.34	2,146,425	21,719	57.9	5.8	26,830	1,241	33,086	2,139	0	0	0
591	PH-1600x350x28x35	673.4	528.62	2,336,102	25,290	58.9	6.1	29,201	1,445	35,558	2,444	0	0	0
592	PH-1600x350x28x40	705.6	553.90	2,523,315	28,861	59.8	6.4	31,541	1,649	38,013	2,748	0	0	0
593	PH-1600x350x28x50	770.0	604.45	2,890,417	36,004	61.3	6.8	36,130	2,057	42,875	3,357	0	0	0
594	PH-1600x400x20x30	548.0	430.18	2,087,831	32,103	61.7	7.7	26,098	1,605	30,698	2,554	0	-	
595	PH-1600x400x20x40	624.0	489.84	2,532,608	42,768	63.7	8.3	31,658	2,138	36,512	3,352	0	-	
596	PH-1600x400x20x50	700.0	549.50	2,965,833	53,433	65.1	8.7	37,073	2,672	42,250	4,150	0	-	
597	PH-1600x400x25x60	850.0	667.25	3,522,733	64,193	64.4	8.7	44,034	3,210	50,650	5,031	0	-	
598	PH-1600x400x25x70	925.0	726.13	3,927,908	74,857	65.2	9.0	49,099	3,743	56,163	5,828	0	-	
599	PH-1600x400x28x28	656.3	515.21	2,242,862	30,149	58.5	6.8	28,036	1,507	34,294	2,543	0	0	0
600	PH-1600x400x28x30	671.2	526.89	2,331,315	32,282	58.9	6.9	29,141	1,614	35,441	2,702	0	0	0
601	PH-1600x400x28x35	708.4	556.09	2,550,445	37,613	60.0	7.3	31,881	1,881	38,296	3,100	0	0	0
602	PH-1600x400x28x40	745.6	585.30	2,766,729	42,945	60.9	7.6	34,584	2,147	41,133	3,498	0	0	0
603	PH-1600x400x28x45	782.8	614.50	2,980,185	48,276	61.7	7.9	37,252	2,414	43,951	3,896	0	0	0
604	PH-1650x300x28x28	614.3	482.24	2,050,103	12,892	57.8	4.6	24,850	859	31,411	1,572	0	0	
605	PH-1650x300x28x30	625.2	490.78	2,119,040	13,791	58.2	4.7	25,685	919	32,277	1,662	0	0	
606	PH-1650x300x28x35	652.4	512.13	2,289,872	16,039	59.2	5.0	27,756	1,069	34,432	1,885	0	0	0
607	PH-1650x300x28x40	679.6	533.49	2,458,555	18,287	60.1	5.2	29,801	1,219	36,574	2,108	0	0	0
608	PH-1650x300x28x50	734.0	576.19	2,789,529	22,784	61.6	5.6	33,812	1,519	40,818	2,554	0	0	0
609	PH-1650x300x28x60	788.4	618.89	3,112,071	27,280	62.8	5.9	37,722	1,819	45,006	3,000	0	0	0
610	PH-1650x350x28x28	642.3	504.22	2,234,283	20,300	59.0	5.6	27,082	1,160	33,681	2,027	0	0	0
611	PH-1650x350x28x30	655.2	514.33	2,315,893	21,728	59.5	5.8	28,071	1,242	34,707	2,149	0	0	0
612	PH-1650x350x28x35	687.4	539.61	2,518,127	25,299	60.5	6.1	30,523	1,446	37,259	2,453	0	0	0
613	PH-1650x350x28x40	719.6	564.89	2,717,818	28,871	61.5	6.3	32,943	1,650	39,794	2,758	0	0	0
614	PH-1650x350x28x50	784.0	615.44	3,109,633	36,013	63.0	6.8	37,693	2,058	44,818	3,366	0	0	0
615	PH-1650x400x28x28	670.3	526.20	2,418,463	30,158	60.1	6.7	29,315	1,508	35,952	2,552	0	0	0
616	PH-1650x400x28x30	685.2	537.88	2,512,745	32,291	60.6	6.9	30,458	1,615	37,137	2,712	0	0	0
617	PH-1650x400x28x35	722.4	567.08	2,746,383	37,622	61.7	7.2	33,289	1,881	40,085	3,110	0	0	0
618	PH-1650x400x28x40	759.6	596.29	2,977,082	42,954	62.6	7.5	36,086	2,148	43,014	3,508	0	0	0
619	PH-1650x400x28x45	796.8	625.49	3,204,860	48,285	63.4	7.8	38,847	2,414	45,925	3,906	0	0	0
620	PH-1700x300x20x30	508.0	398.78	1,990,297	13,609	62.6	5.2	23,415	907	28,478	1,514	0	-	
621	PH-1700x300x20x40	564.0	442.74	2,362,268	18,108	64.7	5.7	27,791	1,207	33,042	1,962	0	-	
622	PH-1700x300x20x50	620.0	486.70	2,725,167	22,607	66.3	6.0	32,061	1,507	37,550	2,410	0	-	
623	PH-1700x300x25x60	755.0	592.68	3,243,452	27,206	65.5	6.0	38,158	1,814	45,123	2,947	0	-	
624	PH-1700x300x25x70	810.0	635.85	3,582,380	31,703	66.5	6.3	42,146	2,114	49,440	3,394	0	-	
625	PH-1700x400x20x30	568.0	445.88	2,408,677	32,109	65.1	7.5	28,337	1,605	33,488	2,564	0	-	
626	PH-1700x400x20x40	644.0	505.54	2,913,495	42,775	67.3	8.1	34,276	2,139	39,682	3,362	0	-	

2.1 Optimized Pos-H

No	Section(mm)	Area	Unit weight	Moment of inertia		Radius of gyration		Elastic section modulus		Plastic section modulus		General Structure	Seismic Structure	
	PH-HxBxt _x t _y	A(cm ²)	(kg/m)	I _x (cm ⁴)	I _y (cm ⁴)	r _x (cm)	r _y (cm)	S _x (cm ³)	S _y (cm ³)	Z _{px} (cm ³)	Z _{py} (cm ³)		SMF*	IMF**
627	PH-1700x400x20x50	720.0	565.20	3,406,000	53,440	68.8	8.6	40,071	2,672	45,800	4,160	0	-	
628	PH-1700x400x25x60	875.0	686.88	4,050,692	64,206	68.0	8.6	47,655	3,210	54,963	5,047	0	-	
629	PH-1700x400x25x70	950.0	745.75	4,512,867	74,870	68.9	8.9	53,093	3,743	60,850	5,844	0	-	
630	PH-1800x300x25x30	615.0	482.78	2,507,445	13,727	63.9	4.7	27,861	915	34,853	1,622	0	-	
631	PH-1800x300x25x40	670.0	525.95	2,918,973	18,224	66.0	5.2	32,433	1,215	39,610	2,069	0	-	
632	PH-1800x300x25x50	725.0	569.13	3,321,042	22,721	67.7	5.6	36,900	1,515	44,313	2,516	0	-	
633	PH-1800x300x25x60	780.0	612.30	3,713,760	27,219	69.0	5.9	41,264	1,815	48,960	2,963	0	-	
634	PH-1800x300x25x70	835.0	655.48	4,097,238	31,716	70.0	6.2	45,525	2,114	53,553	3,409	0	-	
635	PH-1800x400x25x30	675.0	529.88	2,977,425	32,227	66.4	6.9	33,083	1,611	40,163	2,672	0	-	
636	PH-1800x400x25x40	750.0	588.75	3,538,600	42,891	68.7	7.6	39,318	2,145	46,650	3,469	0	-	
637	PH-1800x400x25x50	825.0	647.63	4,086,875	53,555	70.4	8.1	45,410	2,678	53,063	4,266	0	-	
638	PH-1800x400x25x60	900.0	706.50	4,622,400	64,219	71.7	8.4	51,360	3,211	59,400	5,063	0	-	
639	PH-1800x400x25x70	975.0	765.38	5,145,325	74,883	72.6	8.8	57,170	3,744	65,663	5,859	0	-	
640	PH-1900x300x25x30	640.0	502.40	2,871,553	13,740	67.0	4.6	30,227	916	37,990	1,638	0	-	
641	PH-1900x300x25x40	695.0	545.58	3,332,032	18,237	69.2	5.1	35,074	1,216	43,023	2,084	0	-	
642	PH-1900x300x25x50	750.0	588.75	3,782,500	22,734	71.0	5.5	39,816	1,516	48,000	2,531	0	-	
643	PH-1900x300x25x60	805.0	631.93	4,223,068	27,232	72.4	5.8	44,453	1,815	52,923	2,978	0	-	
644	PH-1900x300x25x70	860.0	675.10	4,653,847	31,729	73.6	6.1	48,988	2,115	57,790	3,425	0	-	
645	PH-1900x400x25x30	700.0	549.50	3,396,133	32,240	69.7	6.8	35,749	1,612	43,600	2,688	0	-	
646	PH-1900x400x25x40	775.0	608.38	4,024,058	42,904	72.1	7.4	42,359	2,145	50,463	3,484	0	-	
647	PH-1900x400x25x50	850.0	667.25	4,638,333	53,568	73.9	7.9	48,825	2,678	57,250	4,281	0	-	
648	PH-1900x400x25x60	925.0	726.13	5,239,108	64,232	75.3	8.3	55,149	3,212	63,963	5,078	0	-	
649	PH-1900x400x25x70	1,000.0	785.00	5,826,533	74,896	76.3	8.7	61,332	3,745	70,600	5,875	0	-	
650	PH-2000x300x25x30	665.0	522.03	3,267,662	13,753	70.1	4.5	32,677	917	41,253	1,653	0	-	
651	PH-2000x300x25x40	720.0	565.20	3,779,840	18,250	72.5	5.0	37,798	1,217	46,560	2,100	0	-	
652	PH-2000x300x25x50	775.0	608.38	4,281,458	22,747	74.3	5.4	42,815	1,516	51,813	2,547	0	-	
653	PH-2000x300x25x60	830.0	651.55	4,772,627	27,245	75.8	5.7	47,726	1,816	57,010	2,994	0	-	
654	PH-2000x300x25x70	885.0	694.73	5,253,455	31,742	77.0	6.0	52,535	2,116	62,153	3,441	0	-	
655	PH-2000x400x25x30	725.0	569.13	3,849,842	32,253	72.9	6.7	38,498	1,613	47,163	2,703	0	-	
656	PH-2000x400x25x40	800.0	628.00	4,548,267	42,917	75.4	7.3	45,483	2,146	54,400	3,500	0	-	
657	PH-2000x400x25x50	875.0	686.88	5,232,292	53,581	77.3	7.8	52,323	2,679	61,563	4,297	0	-	
658	PH-2000x400x25x60	950.0	745.75	5,902,067	64,245	78.8	8.2	59,021	3,212	68,650	5,094	0	-	
659	PH-2000x400x25x70	1,025.0	804.63	6,557,742	74,909	80.0	8.5	65,577	3,745	75,663	5,891	0	-	
660	PH-2200x300x25x40	770.0	604.45	4,784,707	18,276	78.8	4.9	43,497	1,218	54,010	2,131	0	-	
661	PH-2200x300x25x50	825.0	647.63	5,396,875	22,773	80.9	5.3	49,063	1,518	59,813	2,578	0	-	
662	PH-2200x300x25x60	880.0	690.80	5,997,493	27,271	82.6	5.6	54,523	1,818	65,560	3,025	0	-	
663	PH-2200x300x25x70	935.0	733.98	6,586,672	31,768	83.9	5.8	59,879	2,118	71,253	3,472	0	-	
664	PH-2200x300x25x80	990.0	777.15	7,164,520	36,266	85.1	6.1	65,132	2,418	76,890	3,919	0	-	
665	PH-2200x400x25x40	850.0	667.25	5,717,933	42,943	82.0	7.1	51,981	2,147	62,650	3,531	0	-	
666	PH-2200x400x25x50	925.0	726.13	6,552,708	53,607	84.2	7.6	59,570	2,680	70,563	4,328	0	-	
667	PH-2200x400x25x60	1,000.0	785.00	7,371,733	64,271	85.9	8.0	67,016	3,214	78,400	5,125	0	-	
668	PH-2200x400x25x70	1,075.0	843.88	8,175,158	74,935	87.2	8.3	74,320	3,747	86,163	5,922	0	-	

2.1 Optimized Pos-H

No	Section(mm)	Area	Unit weight	Moment of inertia		Radius of gyration		Elastic section modulus		Plastic section modulus		General Structure	Seismic Structure	
	PH-HxBxt _x t _t	A(cm ²)	(kg/m)	I _x (cm ⁴)	I _y (cm ⁴)	r _x (cm)	r _y (cm)	S _x (cm ³)	S _y (cm ³)	Z _{px} (cm ³)	Z _{py} (cm ³)		SMF*	IMF**
669	PH-2200x400x25x80	1,150.0	902.75	8,963,133	85,599	88.3	8.6	81,483	4,280	93,850	6,719	○	-	
670	PH-2200x500x25x40	930.0	730.05	6,651,160	83,609	84.6	9.5	60,465	3,344	71,290	5,331	○	-	
671	PH-2200x500x25x50	1,025.0	804.63	7,708,542	104,440	86.7	10.1	70,078	4,178	81,313	6,578	○	-	
672	PH-2200x500x25x60	1,120.0	879.20	8,745,973	125,271	88.4	10.6	79,509	5,011	91,240	7,825	○	-	
673	PH-2200x500x25x70	1,215.0	953.78	9,763,645	146,102	89.6	11.0	88,760	5,844	101,073	9,072	○	-	
674	PH-2200x500x25x80	1,310.0	1,028.35	10,761,747	166,932	90.6	11.3	97,834	6,677	110,810	10,319	○	-	
675	PH-2400x300x30x40	936.0	734.76	6,463,872	18,522	83.1	4.4	53,866	1,235	68,688	2,322	○	-	
676	PH-2400x300x30x50	990.0	777.15	7,184,250	23,018	85.2	4.8	59,869	1,535	74,925	2,768	○	-	
677	PH-2400x300x30x60	1,044.0	819.54	7,892,208	27,513	86.9	5.1	65,768	1,834	81,108	3,213	○	-	
678	PH-2400x300x30x70	1,098.0	861.93	8,587,854	32,009	88.4	5.4	71,565	2,134	87,237	3,659	○	-	
679	PH-2400x300x30x80	1,152.0	904.32	9,271,296	36,504	89.7	5.6	77,261	2,434	93,312	4,104	○	-	
680	PH-2400x400x30x40	1,016.0	797.56	7,577,899	43,189	86.4	6.5	63,149	2,159	78,128	3,722	○	-	
681	PH-2400x400x30x50	1,090.0	855.65	8,565,083	53,851	88.6	7.0	71,376	2,693	86,675	4,518	○	-	
682	PH-2400x400x30x60	1,164.0	913.74	9,535,248	64,513	90.5	7.4	79,460	3,226	95,148	5,313	○	-	
683	PH-2400x400x30x70	1,238.0	971.83	10,488,541	75,175	92.0	7.8	87,405	3,759	103,547	6,109	○	-	
684	PH-2400x400x30x80	1,312.0	1,029.92	11,425,109	85,837	93.3	8.1	95,209	4,292	111,872	6,904	○	-	
685	PH-2400x500x30x40	1,096.0	860.36	8,691,925	83,855	89.1	8.7	72,433	3,354	87,568	5,522	○	-	
686	PH-2400x500x30x50	1,190.0	934.15	9,945,917	104,684	91.4	9.4	82,883	4,187	98,425	6,768	○	-	
687	PH-2400x500x30x60	1,284.0	1,007.94	11,178,288	125,513	93.3	9.9	93,152	5,021	109,188	8,013	○	-	
688	PH-2400x500x30x70	1,378.0	1,081.73	12,389,227	146,342	94.8	10.3	103,244	5,854	119,857	9,259	○	-	
689	PH-2400x500x30x80	1,472.0	1,155.52	13,578,923	167,171	96.0	10.7	113,158	6,687	130,432	10,504	○	-	
690	PH-2600x300x30x40	996.0	781.86	7,933,232	18,567	89.2	4.3	61,025	1,238	78,348	2,367	○	-	
691	PH-2600x300x30x50	1,050.0	824.25	8,783,750	23,063	91.5	4.7	67,567	1,538	85,125	2,813	○	-	
692	PH-2600x300x30x60	1,104.0	866.64	9,620,768	27,558	93.4	5.0	74,006	1,837	91,848	3,258	○	-	
693	PH-2600x300x30x70	1,158.0	909.03	10,444,394	32,054	95.0	5.3	80,341	2,137	98,517	3,704	○	-	
694	PH-2600x300x30x80	1,212.0	951.42	11,254,736	36,549	96.4	5.5	86,575	2,437	105,132	4,149	○	-	
695	PH-2600x400x30x40	1,076.0	844.66	9,244,059	43,234	92.7	6.3	71,108	2,162	88,588	3,767	○	-	
696	PH-2600x400x30x50	1,150.0	902.75	10,409,583	53,896	95.1	6.8	80,074	2,695	97,875	4,563	○	-	
697	PH-2600x400x30x60	1,224.0	960.84	11,566,608	64,558	97.2	7.3	88,897	3,228	107,088	5,358	○	-	
698	PH-2600x400x30x70	1,298.0	1,018.93	12,685,281	75,220	98.9	7.6	97,579	3,761	116,227	6,154	○	-	
699	PH-2600x400x30x80	1,372.0	1,077.02	13,795,749	85,882	100.3	7.9	106,121	4,294	125,292	6,949	○	-	
700	PH-2600x500x30x40	1,156.0	907.46	10,554,885	83,900	95.6	8.5	81,191	3,356	98,828	5,567	○	-	
701	PH-2600x500x30x50	1,250.0	981.25	12,035,417	104,729	98.1	9.2	92,580	4,189	110,625	6,813	○	-	
702	PH-2600x500x30x60	1,344.0	1,055.04	13,492,448	125,558	100.2	9.7	103,788	5,022	122,328	8,058	○	-	
703	PH-2600x500x30x70	1,438.0	1,128.83	14,926,167	146,387	101.9	10.1	114,817	5,855	133,937	9,304	○	-	
704	PH-2600x500x30x80	1,532.0	1,202.62	16,336,763	167,216	103.3	10.4	125,667	6,689	145,452	10,549	○	-	
705	PH-2800x300x35x40	1,192.0	935.72	10,440,277	18,972	93.6	4.0	74,573	1,265	97,856	2,633	○	-	
706	PH-2800x300x35x50	1,245.0	977.33	11,413,375	23,465	95.7	4.3	81,524	1,564	105,038	3,077	○	-	
707	PH-2800x300x35x60	1,298.0	1,018.93	12,372,163	27,958	97.6	4.6	88,373	1,864	112,166	3,521	○	-	
708	PH-2800x300x35x70	1,351.0	1,060.54	13,316,746	32,450	99.3	4.9	95,120	2,163	119,242	3,965	○	-	
709	PH-2800x300x35x80	1,404.0	1,102.14	14,247,232	36,943	100.7	5.1	101,766	2,463	126,264	4,409	○	-	
710	PH-2800x400x35x40	1,272.0	998.52	11,963,904	43,639	97.0	5.9	85,456	2,182	108,896	4,033	○	-	

2.1 Optimized Pos-H

No	Section(mm)	Area A(cm ²)	Unit weight (kg/m)	Moment of inertia		Radius of gyration		Elastic section modulus		Plastic section modulus		General Struc- ture	Seismic Structure	
				I _x (cm ⁴)	I _y (cm ⁴)	r _x (cm)	r _y (cm)	S _x (cm ³)	S _y (cm ³)	Z _{px} (cm ³)	Z _{py} (cm ³)		SMF*	IMF**
711	PH-HxBxt _x t _y	1,345.0	1,055.83	13,304,208	54,298	99.5	6.4	95,030	2,715	118,788	4,827	O	-	
712	PH-2800x400x35x60	1,418.0	1,113.13	14,624,803	64,958	101.6	6.8	104,463	3,248	128,606	5,621	O	-	
713	PH-2800x400x35x70	1,491.0	1,170.44	15,925,833	75,617	103.4	7.1	113,756	3,781	138,352	6,415	O	-	
714	PH-2800x400x35x80	1,564.0	1,227.74	17,207,445	86,277	104.9	7.4	122,910	4,314	148,024	7,209	O	-	
715	PH-2800x500x35x40	1,352.0	1,061.32	13,487,531	84,305	99.9	7.9	96,340	3,372	119,936	5,833	O	-	
716	PH-2800x500x35x50	1,445.0	1,134.33	15,195,042	105,131	102.5	8.5	108,536	4,205	132,538	7,077	O	-	
717	PH-2800x500x35x60	1,538.0	1,207.33	16,877,443	125,958	104.8	9.0	120,553	5,038	145,046	8,321	O	-	
718	PH-2800x500x35x70	1,631.0	1,280.34	18,534,920	146,784	106.6	9.5	132,392	5,871	157,462	9,565	O	-	
719	PH-2800x500x35x80	1,724.0	1,353.34	20,167,659	167,610	108.2	9.9	144,055	6,704	169,784	10,809	O	-	
720	PH-3000x300x35x40	1,262.0	990.67	12,518,931	19,043	99.6	3.9	83,460	1,270	110,126	2,694	O	-	
721	PH-3000x300x35x50	1,315.0	1,032.28	13,640,958	23,536	101.8	4.2	90,940	1,569	117,838	3,138	O	-	
722	PH-3000x300x35x60	1,368.0	1,073.88	14,747,616	28,029	103.8	4.5	98,317	1,869	125,496	3,582	O	-	
723	PH-3000x300x35x70	1,421.0	1,115.49	15,839,010	32,522	105.6	4.8	105,593	2,168	133,102	4,026	O	-	
724	PH-3000x300x35x80	1,474.0	1,157.09	16,915,245	37,015	107.1	5.0	112,768	2,468	140,654	4,470	O	-	
725	PH-3000x400x35x40	1,342.0	1,053.47	14,271,357	43,710	103.1	5.7	95,142	2,185	121,966	4,094	O	-	
726	PH-3000x400x35x50	1,415.0	1,110.78	15,816,792	54,369	105.7	6.2	105,445	2,718	132,588	4,888	O	-	
727	PH-3000x400x35x60	1,488.0	1,168.08	17,341,056	65,029	108.0	6.6	115,607	3,251	143,136	5,682	O	-	
728	PH-3000x400x35x70	1,561.0	1,225.39	18,844,296	75,689	109.9	7.0	125,629	3,784	153,612	6,476	O	-	
729	PH-3000x400x35x80	1,634.0	1,282.69	20,326,659	86,348	111.5	7.3	135,511	4,317	164,014	7,270	O	-	
730	PH-3000x500x35x40	1,422.0	1,116.27	16,023,784	84,377	106.2	7.7	106,825	3,375	133,806	5,894	O	-	
731	PH-3000x500x35x50	1,515.0	1,189.28	17,992,625	105,203	109.0	8.3	119,951	4,208	147,338	7,138	O	-	
732	PH-3000x500x35x60	1,608.0	1,262.28	19,934,496	126,029	111.3	8.9	132,897	5,041	160,776	8,382	O	-	
733	PH-3000x500x35x70	1,701.0	1,335.29	21,849,583	146,855	113.3	9.3	145,664	5,874	174,122	9,626	O	-	
734	PH-3000x500x35x80	1,794.0	1,408.29	23,738,072	167,681	115.0	9.7	158,254	6,707	187,374	10,870	O	-	

2.1 Optimized Pos-H

Asymmetric flexural members

- **Purpose** : Sensitive to depth and reduces material quantity
- **Application** : Remodeling (slim floor)

Optimized Pos-H Beam Asymmetric H-Beam Production Specifications

Pos-H Beam Height (H): Using nominal dimensions

H: 120, 135, 150mm

Pos-H Beam Upper Flange Width (B_t)

B: 150mm

Pos-H Beam Lower Flange Width (B_b)

B: 250mm

Web Thickness (t_w)

12, 15mm

Upper Flange Thickness (t_{f1})

15, 20, 25, 35mm

Lower Flange Thickness (t_{f2})

10, 15, 20mm

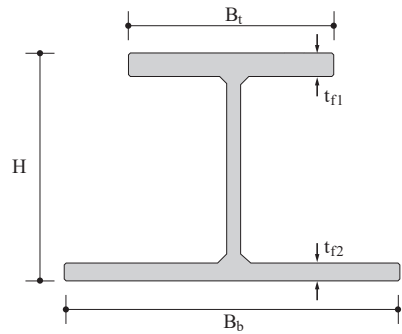

2.1 Optimized Pos-H 20 types of Asymmetric section members

No	Section (mm)	Area	Unit weight	Moment of inertia		Radius of gyration		Elastic section modulus		Plastic section modulus	
				I_x (cm ⁴)	I_y (cm ⁴)	r_x (cm)	r_y (cm)	S_x (cm ³)	S_y (cm ³)	Z_{px} (cm ³)	Z_{py} (cm ³)
735	PH-(120x150x250)x12x15x10	58.9	46.2	1,461	1,725	5.0	5.4	260	271	282	244
736	PH-(120x150x250)x12x25x15	84.6	66.4	1,953	2,657	4.8	5.6	341	423	394	378
737	PH-(120x150x250)x12x35x20	110.3	86.6	2,291	3,589	4.6	5.7	402	570	487	512
738	PH-(120x150x250)x15x15x10	61.8	48.5	1,482	1,727	4.9	5.3	263	271	289	246
739	PH-(120x150x250)x15x25x15	87.0	68.3	1,966	2,659	4.8	5.5	344	423	399	380
740	PH-(120x150x250)x15x35x20	112.3	88.1	2,298	3,590	4.5	5.7	403	569	490	513
741	PH-(135x150x250)x12x15x10	60.7	47.6	1,917	1,726	5.6	5.3	302	241	327	245
742	PH-(135x150x250)x12x20x15	79.5	62.4	2,421	2,517	5.5	5.6	400	338	423	350
743	PH-(135x150x250)x12x25x15	86.4	67.8	2,593	2,658	5.5	5.5	401	378	458	378
744	PH-(135x150x250)x12x35x20	112.1	88.0	3,083	3,590	5.2	5.7	477	510	570	512
745	PH-(135x150x250)x15x15x10	64.0	50.2	1,950	1,727	5.5	5.2	307	242	336	247
746	PH-(135x150x250)x15x25x15	89.3	70.1	2,614	2,659	5.4	5.5	405	378	465	380
747	PH-(135x150x250)x15x35x20	114.5	89.9	3,097	3,591	5.2	5.6	480	510	575	514
748	PH-(150x150x250)x12x15x10	62.5	49.1	2,441	1,726	6.2	5.3	345	218	373	245
749	PH-(150x150x250)x12x20x10	69.4	54.5	2,679	1,866	6.2	5.2	349	255	413	273
750	PH-(150x150x250)x12x25x15	88.2	69.2	3,329	2,658	6.1	5.5	462	341	524	379
751	PH-(150x150x250)x12x35x20	113.9	89.4	4,002	3,590	5.9	5.6	554	462	655	513
752	PH-(150x150x250)x15x15x10	66.3	52.0	2,490	1,727	6.1	5.1	352	218	384	248
753	PH-(150x150x250)x15x25x15	91.5	71.8	3,363	2,659	6.1	5.4	467	341	533	381
754	PH-(150x150x250)x15x35x20	116.8	91.6	4,024	3,591	5.9	5.5	558	461	662	515

2.1 Optimized Pos-H 75 types of Compression members – H shape

No	Section (mm)	Area	Unit weight	Moment of inertia		Radius of gyration		Elastic section modulus		Plastic section modulus		Seismic compact section
				I_x (cm ⁴)	I_y (cm ⁴)	r_x (cm)	r_y (cm)	S_x (cm ³)	S_y (cm ³)	Z_{px} (cm ³)	Z_{py} (cm ³)	
755	PH-300x300x10x15	117.0	91.85	19,933	6,752	13.1	7.6	1,329	450	1,465	682	-
756	PH-300x300x15x15	130.5	102.44	20,753	6,758	12.6	7.2	1,384	451	1,556	690	-
757	PH-300x300x15x20	159.0	124.82	25,757	9,007	12.7	7.5	1,717	600	1,934	915	-
758	PH-300x300x15x25	187.5	147.19	30,391	11,257	12.7	7.7	2,026	750	2,297	1,139	O
759	PH-300x300x20x30	228.0	178.98	35,244	13,516	12.4	7.7	2,350	901	2,718	1,374	O
760	PH-350x350x10x15	137.0	107.55	32,209	10,721	15.3	8.8	1,841	613	2,015	927	-
761	PH-350x350x15x15	153.0	120.11	33,575	10,728	14.8	8.4	1,919	613	2,143	937	-
762	PH-350x350x15x20	186.5	146.40	41,886	14,300	15.0	8.8	2,393	817	2,670	1,242	-
763	PH-350x350x15x25	220.0	172.70	49,677	17,873	15.0	9.0	2,839	1,021	3,181	1,548	O
764	PH-350x350x20x30	268.0	210.38	57,982	21,457	14.7	8.9	3,313	1,226	3,781	1,867	O
765	PH-400x400x15x15	175.5	137.77	50,822	16,010	17.0	9.6	2,541	801	2,823	1,221	-
766	PH-400x400x15x20	214.0	167.99	63,645	21,343	17.2	10.0	3,182	1,067	3,526	1,620	-
767	PH-400x400x15x25	252.5	198.21	75,776	26,677	17.3	10.3	3,789	1,334	4,209	2,020	-
768	PH-400x400x20x30	308.0	241.78	88,871	32,023	17.0	10.2	4,444	1,601	5,018	2,434	O
769	PH-400x400x20x35	346.0	271.61	99,533	37,355	17.0	10.4	4,977	1,868	5,655	2,833	O
770	PH-400x400x20x40	384.0	301.44	109,568	42,688	16.9	10.5	5,478	2,134	6,272	3,232	O
771	PH-400x400x25x45	437.5	343.44	120,236	48,040	16.6	10.5	6,012	2,402	6,991	3,648	O
772	PH-400x400x25x50	475.0	372.88	128,958	53,372	16.5	10.6	6,448	2,669	7,563	4,047	O
773	PH-400x400x25x55	512.5	402.31	137,118	58,704	16.4	10.7	6,856	2,935	8,116	4,445	O
774	PH-400x400x30x60	564.0	442.74	145,648	64,063	16.1	10.7	7,282	3,203	8,748	4,863	O
775	PH-400x400x30x65	601.0	471.79	152,644	69,394	15.9	10.7	7,632	3,470	9,257	5,261	O
776	PH-400x400x30x70	638.0	500.83	159,141	74,725	15.8	10.8	7,957	3,736	9,747	5,659	O
777	PH-450x450x15x20	241.5	189.58	91,880	30,387	19.5	11.2	4,084	1,351	4,500	2,048	-
778	PH-450x450x15x25	285.0	223.73	109,719	37,980	19.6	11.5	4,876	1,688	5,381	2,554	-
779	PH-450x450x20x30	348.0	273.18	129,159	45,589	19.3	11.4	5,740	2,026	6,431	3,077	-
780	PH-450x450x20x35	391.0	306.94	145,094	53,182	19.3	11.7	6,449	2,364	7,258	3,582	O
781	PH-450x450x20x40	434.0	340.69	160,212	60,775	19.2	11.8	7,121	2,701	8,065	4,087	O
782	PH-450x450x25x45	495.0	388.58	176,479	68,391	18.9	11.8	7,844	3,040	9,011	4,613	O
783	PH-450x450x25x50	537.5	421.94	189,870	75,983	18.8	11.9	8,439	3,377	9,766	5,117	O
784	PH-450x450x25x55	580.0	455.30	202,517	83,576	18.7	12.0	9,001	3,714	10,499	5,622	O
785	PH-450x450x30x60	639.0	501.62	215,939	91,199	18.4	11.9	9,597	4,053	11,347	6,149	O
786	PH-450x450x30x65	681.0	534.59	227,031	98,791	18.3	12.0	10,090	4,391	12,029	6,653	O
787	PH-450x450x30x70	723.0	567.56	237,450	106,382	18.1	12.1	10,553	4,728	12,691	7,157	O
788	PH-500x500x20x30	388.0	304.58	180,097	62,529	21.5	12.7	7,204	2,501	8,018	3,794	-
789	PH-500x500x20x35	436.0	342.26	202,805	72,945	21.6	12.9	8,112	2,918	9,062	4,418	O
790	PH-500x500x20x40	484.0	379.94	224,481	83,361	21.5	13.1	8,979	3,334	10,082	5,042	O
791	PH-500x500x25x45	552.5	433.71	248,021	93,803	21.2	13.0	9,921	3,752	11,288	5,689	O
792	PH-500x500x25x50	600.0	471.00	267,500	104,219	21.1	13.2	10,700	4,169	12,250	6,313	O

2.1 Optimized Pos-H

No	Section (mm)	Area	Unit weight	Moment of inertia		Radius of gyration		Elastic section modulus		Plastic section modulus		Seismic compact section
	PH-H x B x t _w x t _f			A (cm ²)	(kg/m)	I _x (cm ⁴)	I _y (cm ⁴)	r _x (cm)	r _y (cm)	S _x (cm ³)	S _y (cm ³)	
793	PH-500x500x25x55	647.5	508.29	286,029	114,634	21.0	13.3	11,441	4,585	13,188	6,936	O
794	PH-500x500x30x60	714.0	560.49	305,918	125,086	20.7	13.2	12,237	5,003	14,283	7,586	O
795	PH-500x500x30x65	761.0	597.39	322,442	135,500	20.6	13.3	12,898	5,420	15,164	8,208	O
796	PH-500x500x30x70	808.0	634.28	338,097	145,914	20.5	13.4	13,524	5,837	16,022	8,831	O
797	PH-550x550x20x30	428.0	335.98	242,936	83,220	23.8	13.9	8,834	3,026	9,781	4,587	-
798	PH-550x550x20x35	481.0	377.59	274,104	97,084	23.9	14.2	9,967	3,530	11,066	5,342	-
799	PH-550x550x20x40	534.0	419.19	304,001	110,948	23.9	14.4	11,055	4,034	12,325	6,097	O
800	PH-550x550x25x45	610.0	478.85	336,707	124,841	23.5	14.3	12,244	4,540	13,821	6,878	O
801	PH-550x550x25x50	662.5	520.06	363,880	138,704	23.4	14.5	13,232	5,044	15,016	7,633	O
802	PH-550x550x25x55	715.0	561.28	389,872	152,568	23.4	14.6	14,177	5,548	16,184	8,388	O
803	PH-550x550x30x60	789.0	619.37	418,022	166,472	23.0	14.5	15,201	6,054	17,557	9,172	O
804	PH-550x550x30x65	841.0	660.19	441,504	180,334	22.9	14.6	16,055	6,558	18,662	9,926	O
805	PH-550x550x30x70	893.0	701.01	463,894	194,196	22.8	14.7	16,869	7,062	19,741	10,680	O
806	PH-600x600x20x30	468.0	367.38	318,924	108,036	26.1	15.2	10,631	3,601	11,718	5,454	-
807	PH-600x600x20x35	526.0	412.91	360,428	126,035	26.2	15.5	12,014	4,201	13,270	6,353	-
808	PH-600x600x20x40	584.0	458.44	400,395	144,035	26.2	15.7	13,346	4,801	14,792	7,252	-
809	PH-600x600x25x45	667.5	523.99	444,381	162,066	25.8	15.6	14,813	5,402	16,611	8,180	O
810	PH-600x600x25x50	725.0	569.13	481,042	180,065	25.8	15.8	16,035	6,002	18,063	9,078	O
811	PH-600x600x25x55	782.5	614.26	516,265	198,064	25.7	15.9	17,209	6,602	19,486	9,977	O
812	PH-600x600x30x60	864.0	678.24	554,688	216,108	25.3	15.8	18,490	7,204	21,168	10,908	O
813	PH-600x600x30x65	921.0	722.99	586,841	234,106	25.2	15.9	19,561	7,804	22,522	11,806	O
814	PH-600x600x30x70	978.0	767.73	617,654	252,104	25.1	16.1	20,588	8,403	23,847	12,704	O
815	PH-650x650x25x50	787.5	618.19	621,016	228,926	28.1	17.0	19,108	7,044	21,391	10,648	O
816	PH-650x650x25x55	850.0	667.25	667,427	251,810	28.0	17.2	20,536	7,748	23,094	11,703	O
817	PH-650x650x30x60	939.0	737.12	718,354	274,744	27.7	17.1	22,103	8,454	25,117	12,794	O
818	PH-650x650x30x65	1,001.0	785.79	761,077	297,627	27.6	17.2	23,418	9,158	26,744	13,848	O
819	PH-650x650x30x70	1,063.0	834.46	802,189	320,511	27.5	17.4	24,683	9,862	28,341	14,902	O
820	PH-700x700x30x50	880.0	690.80	794,833	285,968	30.1	18.0	22,710	8,171	25,450	12,385	O
821	PH-700x700x30x55	947.0	743.40	854,134	314,549	30.0	18.2	24,404	8,987	27,443	13,608	O
822	PH-700x700x40x60	1,072.0	841.52	927,717	343,309	29.4	17.9	26,506	9,809	30,244	14,932	O
823	PH-700x700x40x65	1,138.0	893.33	982,272	371,887	29.4	18.1	28,065	10,625	32,142	16,153	O
824	PH-700x700x40x70	1,204.0	945.14	1,034,945	400,465	29.3	18.2	29,570	11,442	34,006	17,374	O
825	PH-800x800x30x50	1,010.0	792.85	1,212,417	426,824	34.6	20.6	30,310	10,671	33,675	16,158	-
826	PH-800x800x30x55	1,087.0	853.30	1,305,401	469,489	34.7	20.8	32,635	11,737	36,351	17,755	-
827	PH-800x800x40x60	1,232.0	967.12	1,421,931	512,363	34.0	20.4	35,548	12,809	40,144	19,472	O
828	PH-800x800x40x65	1,308.0	1,026.78	1,508,501	555,024	34.0	20.6	37,713	13,876	42,709	21,068	O
829	PH-800x800x40x70	1,384.0	1,086.44	1,592,525	597,685	33.9	20.8	39,813	14,942	45,236	22,664	O

2.1 Optimized Pos-H

Compression members – π shape

- **Purpose** : To complement weak-axis buckling in members with high axial loads and large slenderness ratios of columns
- **Application** : Underground floor columns in top-down construction method, warehouse columns, etc.

Optimized Pos- π Beam Production Specifications

Pos- π Beam Height (H): Using nominal dimensions

H: 400~700mm series

Pos- π Beam Flange Width (B): Using nominal dimensions

B: 400~700mm series

Web Thickness (t_w)

15, 20, 30, 40mm (4 types)

Flange Thickness (t_f)

15, 20, 25, 30, 35, 40, 45, 50, 60, 70mm (10 types)

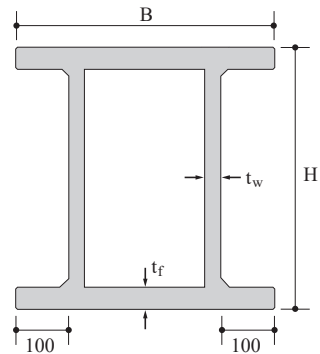

2.1 Optimized Pos-H 40 types of Compression members – Π shape

No	Section(mm)	Area	Unit weight	Moment of inertia		Radius of gyration		Elastic section modulus		Plastic section modulus	
	Π -HxBxt _w t _t	A(cm ²)	(kg/m)	I _x (cm ⁴)	I _y (cm ⁴)	r _x (cm)	r _y (cm)	S _x (cm ³)	S _y (cm ³)	Z _{px} (cm ³)	Z _{py} (cm ³)
830	Π -400x400x15x15	231.0	181.34	57,153	25,518	15.7	10.5	2,858	1,276	3,337	2,227
831	Π -400x400x15x20	268.0	210.38	69,477	30,594	16.1	10.7	3,474	1,530	4,012	2,599
832	Π -400x400x15x25	305.0	239.43	81,135	35,670	16.3	10.8	4,057	1,784	4,669	2,971
833	Π -400x400x20x30	376.0	295.16	95,421	43,061	15.9	10.7	4,771	2,153	5,596	3,624
834	Π -400x400x20x35	412.0	323.42	105,522	48,069	16.0	10.8	5,276	2,403	6,199	3,988
835	Π -400x400x20x40	448.0	351.68	115,029	53,077	16.0	10.9	5,751	2,654	6,784	4,352
836	Π -400x400x30x45	546.0	428.61	128,926	61,578	15.4	10.6	6,446	3,079	7,832	5,181
837	Π -400x400x30x50	580.0	455.30	136,833	66,473	15.4	10.7	6,842	3,324	8,350	5,530
838	Π -400x400x40x60	704.0	552.64	154,795	78,635	14.8	10.6	7,740	3,932	9,728	6,592
839	Π -400x400x40x70	788.0	602.88	166,464	88,256	14.7	10.7	8,323	4,413	10,592	7,264
840	Π -450x450x15x20	303.0	237.86	100,495	47,380	18.2	12.5	4,466	2,106	5,131	3,470
841	Π -450x450x15x25	345.0	270.83	117,719	54,559	18.5	12.6	5,232	2,425	5,981	3,941
842	Π -450x450x20x30	426.0	334.41	139,046	66,246	18.1	12.5	6,180	2,944	7,191	4,832
843	Π -450x450x20x35	467.0	366.60	154,239	73,309	18.2	12.5	6,855	3,258	7,980	5,292
844	Π -450x450x20x40	508.0	398.78	168,654	80,372	18.2	12.6	7,496	3,572	8,749	5,752
845	Π -450x450x30x45	621.0	487.49	190,087	94,642	17.5	12.3	8,448	4,206	10,145	6,932
846	Π -450x450x30x50	660.0	518.10	202,375	101,505	17.5	12.4	8,994	4,511	10,838	7,373
847	Π -450x450x40x60	804.0	631.14	230,913	120,583	16.9	12.2	10,263	5,359	12,708	8,847
848	Π -450x450x40x70	878.0	689.23	249,863	133,985	16.9	12.4	11,105	5,955	13,892	9,692
849	Π -500x500x20x30	476.0	373.66	194,295	97,055	20.2	14.3	7,772	3,882	8,986	6,214
850	Π -500x500x20x35	522.0	409.77	216,057	106,686	20.3	14.3	8,642	4,267	9,987	6,783
851	Π -500x500x20x40	568.0	445.88	236,829	116,317	20.4	14.3	9,473	4,653	10,964	7,352
852	Π -500x500x30x45	696.0	546.36	268,123	138,768	19.6	14.1	10,725	5,551	12,759	8,946
853	Π -500x500x30x50	740.0	580.90	286,167	148,087	19.7	14.1	11,447	5,923	13,650	9,490
854	Π -500x500x40x60	904.0	709.64	328,781	176,781	19.1	14.0	13,151	7,071	16,088	11,452
855	Π -500x500x40x70	988.0	775.58	357,537	194,889	19.0	14.0	14,301	7,796	17,642	12,494
856	Π -600x600x20x30	576.0	452.16	345,168	186,048	24.5	18.0	11,506	6,202	13,176	9,504
857	Π -600x600x20x35	632.0	496.12	385,241	202,603	24.7	17.9	12,841	6,753	14,674	10,328
858	Π -600x600x20x40	688.0	540.08	423,829	219,157	24.8	17.8	14,128	7,305	16,144	11,152
859	Π -600x600x30x45	846.0	664.11	483,071	266,958	23.9	17.8	16,102	8,899	18,887	13,761
860	Π -600x600x30x50	900.0	706.50	517,500	282,900	24.0	17.7	17,250	9,430	20,250	14,550
861	Π -600x600x40x60	1,104.0	866.64	600,768	340,928	23.3	17.6	20,026	11,364	24,048	17,712
862	Π -600x600x40x70	1,208.0	948.28	658,211	371,723	23.3	17.5	21,940	12,391	26,492	19,224
863	Π -700x700x20x30	676.0	530.66	559,041	319,041	28.8	21.7	15,973	9,115	18,166	13,494
864	Π -700x700x20x35	742.0	582.47	625,575	345,319	29.0	21.6	17,874	9,866	20,262	14,623
865	Π -700x700x20x40	808.0	634.28	690,029	371,597	29.2	21.4	19,715	10,617	22,324	15,752
866	Π -700x700x30x45	996.0	781.86	790,268	459,648	28.2	21.5	22,579	13,133	26,214	19,626
867	Π -700x700x30x50	1,060.0	832.10	848,833	484,913	28.3	21.4	24,252	13,855	28,150	20,710
868	Π -700x700x40x60	1,304.0	1,023.64	992,755	589,075	27.6	21.3	28,364	16,831	33,608	25,372
869	Π -700x700x40x70	1,428.0	1,120.98	1,093,484	637,756	27.7	21.1	31,242	18,222	37,142	27,454

2.2 Standardized Pos-H

The Excellence of Standardized Pos-H

POSCO World Premium H-Beam

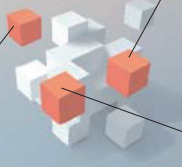

- Standardization**
Standardized members corresponding one-to-one with RH beam
- Economic efficiency**
With performance equal to or better than RH beam material savings of about 8–10%
- Convenience**
All flexural members are compact sections

Standardized Pos-H beam member production specifications

Depth (H) of Pos-H beam

$$H = h_w + 2 \times t_f$$

Series : 300, 350, 400, 450, 500, 600, 700, 800, 900mm, etc.

Width (B) of Pos-H beam: Use nominal dimensions

Adjusted in 10mm increments, similar to RH-shaped steel

ex) 299, 301, 302, 305 → 300mm

398, 402, 403, 405, 407, 408 → 400mm, etc.

Web thickness (t_w) : Integer units

Adjustment priority 1: Maintain Compact Section Type

Adjustment priority 2: Maintain performance equivalent to the plastic section modulus of RH

Flange thickness (t_f)

Adjust similarly to RH

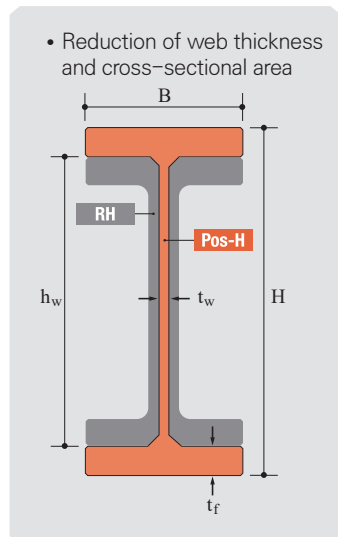

2.2 Standardized Pos-H 84 types of flexural compression members

- Members corresponding to RH in KS standards (36 types)
- Members corresponding to RH not in KS standards (16 types)
- Additional members not in RH (10 types)

No	Nominal Dimensions (m)	Rolled H Section		Pos-H Section											
		Section (mm)		Unit weight (kg/m)	Section (mm)	Area (cm ²)	Unit weight (kg/m)	Moment of inertia (cm ⁴)		Radius of gyration (cm)		Elastic section modulus (cm ³)		Plastic section modulus (cm ³)	
		RH-H x B x t _w x t _f	r	PH-H x B x t _w x t _f	A	(kg/m)	I _x	I _y	r _x	r _y	S _x	S _y	Z _{px}	Z _{py}	
870	300 x 300	H-294x302x12x12	18	84.5	PH-300x300x12x12	105.1	82.52	17,041	5,404	12.7	7.2	1,136	360	1,265	550
871		H-298x299x9x14	18	87.0	PH-300x300x9x15	114.3	89.73	19,769	6,752	13.2	7.7	1,318	450	1,447	680
872		H-300x300x10x15	18	94.0	PH-300x300x10x15	117.0	91.85	19,933	6,752	13.1	7.6	1,329	450	1,465	682
873		H-300x305x15x15	18	105.8	PH-300x300x15x15	130.5	102.44	20,753	6,758	12.6	7.2	1,384	451	1,556	690
874		H-304x301x11x17	18	105.8	PH-300x300x10x18	134.4	105.50	23,034	8,102	13.1	7.8	1,536	540	1,697	817
875		H-310x305x15x20	18	129.7	PH-300x300x16x20	161.6	126.86	25,903	9,009	12.7	7.5	1,727	601	1,950	917
876		H-310x310x20x20	18	141.9	PH-300x300x20x20	172.0	135.02	26,489	9,017	12.4	7.2	1,766	601	2,018	926
877		350 x 350	H-338x351x13x13	20	106.2	PH-350x350x9x15	133.8	105.03	31,936	10,721	15.4	9.0	1,825	613	1,989
878	H-344x348x10x16		20	114.6	PH-350x350x10x16	143.8	112.88	33,939	11,436	15.4	8.9	1,939	653	2,123	988
879	H-344x354x16x16		20	130.8	PH-350x350x16x16	162.9	127.86	35,547	11,444	14.8	8.4	2,031	654	2,275	1,000
880	H-350x350x12x19		20	136.5	PH-350x350x10x20	171.0	134.24	40,644	14,294	15.4	9.1	2,323	817	2,550	1,233
881	H-350x357x19x19		20	155.7	PH-350x350x18x20	195.8	153.70	42,630	14,307	14.8	8.5	2,436	818	2,742	1,250
882	400x 200	H-400x200x8x13	16	66.0	PH-424x200x8x12	80.0	62.80	24,642	1,602	17.6	4.5	1,162	160	1,309	246
883		H-404x201x9x15	16	75.5	PH-424x230x8x12	87.2	68.45	27,698	2,435	17.8	5.3	1,307	212	1,457	324
884	400x 300	H-386x299x9x14	22	94.3	PH-430x250x9x15	111.0	87.14	37,106	3,909	18.3	5.9	1,726	313	1,916	477
885		H-390x300x10x16	22	106.7	PH-432x280x9x16	125.6	98.60	43,584	5,856	18.6	6.8	2,018	418	2,224	635
886	400 x 400	H-388x402x15x15	22	140.1	PH-400x400x15x15	175.5	137.77	50,822	16,010	17.0	9.6	2,541	801	2,823	1,221
887		H-394x398x11x18	22	146.6	PH-400x400x12x18	187.7	147.33	57,394	19,205	17.5	10.1	2,870	960	3,148	1,453
888		H-394x405x18x18	22	168.3	PH-400x400x18x18	209.5	164.47	59,806	19,218	16.9	9.6	2,990	961	3,347	1,489
889		H-400x400x13x21	22	171.7	PH-400x400x16x20	217.6	170.82	64,034	21,346	17.2	9.9	3,202	1,067	3,558	1,623
890		H-400x408x21x21	22	196.8	PH-400x400x12x25	242.0	189.97	74,704	26,672	17.6	10.5	3,735	1,334	4,118	2,013
891		H-406x403x16x24	22	200.1	PH-400x400x15x25	252.5	198.21	75,776	26,677	17.3	10.3	3,789	1,334	4,209	2,020
892		H-414x405x18x28	22	231.9	PH-400x400x16x30	294.4	231.10	87,561	32,012	17.2	10.4	4,378	1,601	4,902	2,422
893		H-428x407x20x35	22	283.1	PH-400x400x25x35	362.5	284.56	101,030	37,376	16.7	10.2	5,052	1,869	5,791	2,852
894		H-458x417x30x50	22	414.9	PH-450x450x30x45	513.0	402.71	178,423	68,425	18.6	11.5	7,930	3,041	9,173	4,637
895		H-498x432x45x70	22	604.5	PH-450x450x45x70	769.5	604.06	241,174	106,548	17.7	11.8	10,719	4,735	13,051	7,244
896	450 x 200	H-446x199x8x12	18	66.2	PH-474x190x8x12	81.6	64.06	30,413	1,374	19.3	4.1	1,283	145	1,458	224
897		H-450x200x9x14	18	76.0	PH-474x220x8x12	88.8	69.71	34,256	2,132	19.6	4.9	1,445	194	1,625	298
898	450 x 300	H-434x299x10x15	24	106.0	PH-480x280x9x15	124.5	97.73	52,257	5,491	20.5	6.6	2,177	392	2,409	597
899		H-440x300x11x18	24	123.5	PH-486x280x9x18	141.3	110.92	62,056	6,588	21.0	6.8	2,554	471	2,814	715
900	500 x 200	H-496x199x9x14	20	79.5	PH-524x220x8x12	92.8	72.85	42,943	2,132	21.5	4.8	1,639	194	1,852	298
901		H-500x200x10x16	20	89.7	PH-532x200x8x16	104.0	81.64	50,948	2,135	22.1	4.5	1,915	214	2,151	328
902	H-506x201x11x19	20	103.1	PH-536x210x9x18	120.6	94.67	60,109	2,781	22.3	4.8	2,243	265	2,521	407	

2.2 Standardized Pos-H

- Members corresponding to RH in KS standards (36 types)
- Members corresponding to RH not in KS standards (16 types)
- Additional members not in RH (10 types)

No	Nominal Dimensions (mm)	Rolled H Section		Pos-H Section											
		Section (mm)		Unit weight	Section (mm)	Area	Unit weight	Moment of inertia		Radius of gyration		Elastic section modulus		Plastic section modulus	
		RH-H x B x t _w x t _f	r	(kg/m)				I _x (cm ⁴)	I _y (cm ⁴)	r _x (cm)	r _y (cm)	S _x (cm ³)	S _y (cm ³)	Z _{px} (cm ³)	Z _{py} (cm ³)
903	500 x 300	H-482x300x11x15	26	114.2	PH-530x290x9x15	132.0	103.62	67,078	6,100	22.5	6.8	2,531	421	2,803	641
904		H-488x300x11x18	26	128.4	PH-536x290x9x18	149.4	117.28	79,436	7,320	23.1	7.0	2,964	505	3,266	767
905		H-596x199x10x15	22	94.6	PH-630x200x8x15	108.0	84.78	71,145	2,003	25.7	4.3	2,259	200	2,565	310
906	600 x 200	H-600x200x11x17	22	105.5	PH-632x210x9x16	121.2	95.14	79,963	2,473	25.7	4.5	2,530	236	2,880	365
907		H-606x201x12x20	22	119.7	PH-640x200x10x20	140.0	109.90	94,907	2,672	26.0	4.4	2,966	267	3,380	415
908		H-612x202x13x23	22	134.0	PH-640x220x12x20	160.0	125.60	106,197	3,558	25.8	4.7	3,319	323	3,808	506
909		H-582x300x12x17	28	137.0	PH-636x280x9x18	154.8	121.52	112,472	6,589	27.0	6.5	3,537	471	3,925	718
910	600 x 300				PH-636x300x9x18	162.0	127.17	119,349	8,104	27.1	7.1	3,753	540	4,147	822
911		H-588x300x12x20	28	151.1	PH-640x300x9x20	174.0	136.59	131,560	9,004	27.5	7.2	4,111	600	4,530	912
912					PH-640x320x9x20	182.0	142.87	139,251	10,926	27.7	7.7	4,352	683	4,778	1,036
913		H-594x302x14x23	28	174.6	PH-650x280x10x25	200.0	157.00	154,792	9,152	27.8	6.8	4,763	654	5,275	995
914		H-692x300x13x20	28	166.0	PH-740x300x10x20	190.0	149.15	184,143	9,006	31.1	6.9	4,977	600	5,545	918
915					PH-740x320x10x20	198.0	155.43	194,514	10,929	31.3	7.4	5,257	683	5,833	1,042
916	700 x 300	H-700x300x13x24	28	184.9	PH-750x290x10x25	215.0	168.78	219,198	10,168	31.9	6.9	5,845	701	6,481	1,069
917					PH-750x310x10x25	225.0	176.63	232,344	12,419	32.1	7.4	6,196	801	6,844	1,219
918		H-708x302x15x28	28	214.8	PH-760x270x12x30	246.0	193.11	250,246	9,852	31.9	6.3	6,585	730	7,383	1,119
919					PH-760x300x12x30	264.0	207.24	274,240	13,510	32.2	7.2	7,217	901	8,040	1,375
920		H-792x300x14x22	28	191.1	PH-850x280x10x25	220.0	172.70	280,958	9,153	35.7	6.5	6,611	654	7,375	1,000
921					PH-850x300x10x25	230.0	180.55	297,979	11,257	36.0	7.0	7,011	750	7,788	1,145
922	800 x 300	H-800x300x14x26	28	209.9	PH-850x320x10x25	240.0	188.40	315,000	13,660	36.2	7.5	7,412	854	8,200	1,300
923					PH-850x340x10x25	250.0	196.25	332,021	16,383	36.4	8.1	7,812	964	8,613	1,465
924		H-808x302x16x30	28	241.5	PH-860x300x12x30	276.0	216.66	361,340	13,512	36.2	7.0	8,403	901	9,390	1,379
925					PH-860x320x12x30	288.0	226.08	382,016	16,396	36.4	7.5	8,884	1,025	9,888	1,565
926		H-890x299x15x23	28	212.6	PH-950x280x12x25	248.0	194.68	372,442	9,160	38.8	6.1	7,841	654	8,905	1,012
927					PH-950x300x12x25	258.0	202.53	393,838	11,263	39.1	6.6	8,291	751	9,368	1,157
928	900 x 300	H-900x300x16x28	28	243.2	PH-960x290x12x30	282.0	221.37	449,262	12,207	39.9	6.6	9,360	842	10,521	1,294
929					PH-960x310x12x30	294.0	230.79	475,218	14,908	40.2	7.1	9,900	962	11,079	1,474
930		H-912x302x18x34	28	285.7	PH-970x310x12x35	325.0	255.13	547,389	17,391	41.0	7.3	11,286	1,122	12,575	1,714
931		H-918x303x19x37	28	307.2	PH-970x310x16x35	361.0	283.39	571,689	17,409	39.8	6.9	11,787	1,123	13,385	1,739

2.2 Standardized Pos-H for Floor height restriction

No	Nominal Dimensions (mm)	Rolled H Section			Pos-H Section										
		Section (mm)		Unit weight	Section (mm)	Area	Unit weight	Moment of inertia		Radius of gyration		Elastic section modulus		Plastic section modulus	
		RH-H x B x t ₁ x t ₂	r	(kg/m)				I _x (cm ⁴)	I _y (cm ⁴)	r _x (cm)	r _y (cm)	S _{xx} (cm ³)	S _{yy} (cm ³)	Z _{px} (cm ³)	Z _{py} (cm ³)
932	500x200	H-496x199x9x14	20	79.5	PH-500x200x8x15	97.6	76.62	42,217	2,002	20.8	4.5	1,689	200	1,897	308
933		H-500x200x10x16	20	89.7	PH-500x220x8x16	107.8	84.65	48,078	2,841	21.1	5.1	1,923	258	2,142	395
934		H-506x201x11x19	20	103.1	PH-500x210x9x20	125.4	98.44	55,712	3,090	21.1	5.0	2,228	294	2,492	450
935	500x300	H-482x300x11x15	26	114.2	PH-500x290x9x16	134.9	105.91	62,055	6,507	21.4	6.9	2,482	449	2,739	682
936		H-488x300x11x18	26	128.4	PH-500x290x9x20	157.4	123.56	74,155	8,132	21.7	7.2	2,966	561	3,260	850
937	600x200	H-596x199x10x15	22	94.6	PH-600x210x9x15	114.3	89.73	67,802	2,319	24.4	4.5	2,260	221	2,574	342
938		H-600x200x11x17	22	105.5	PH-600x230x9x16	124.7	97.91	76,514	3,248	24.8	5.1	2,550	282	2,875	435
939		H-606x201x12x20	22	119.7	PH-600x220x10x20	144.0	113.04	88,672	3,554	24.8	5.0	2,956	323	3,336	498
940		H-612x202x13x23	22	134.0	PH-600x240x10x20	152.0	119.32	95,403	4,613	25.1	5.5	3,180	384	3,568	590
941	600x300	H-582x300x12x17	28	137.0	PH-600x280x10x20	168.0	131.88	108,864	7,322	25.5	6.6	3,629	523	4,032	798
942		H-588x300x12x20	28	151.1	PH-600x320x10x20	184.0	144.44	122,325	10,927	25.8	7.7	4,078	683	4,496	1,038
943		H-594x302x14x23	28	174.6	PH-600x310x10x25	210.0	164.85	142,063	12,418	26.0	7.7	4,735	801	5,213	1,215
944	700x300	H-692x300x13x20	28	166.0	PH-700x270x10x25	200.0	157.00	176,729	8,207	29.7	6.4	5,049	608	5,613	928
945		H-700x300x13x24	28	184.9	PH-700x320x10x25	225.0	176.63	205,219	13,659	30.2	7.8	5,863	854	6,456	1,296
946		H-708x302x15x28	28	214.8	PH-700x300x12x30	256.8	201.59	228,354	13,509	29.8	7.3	6,524	901	7,259	1,373
947	800x300	H-792x300x14x22	28	191.1	PH-800x300x10x25	225.0	176.63	260,469	11,256	34.0	7.1	6,512	750	7,219	1,144
948		H-800x300x14x26	28	209.9	PH-800x290x10x30	248.0	194.68	291,811	12,201	34.3	7.0	7,295	841	8,068	1,280
949		H-808x302x16x30	28	241.5	PH-800x290x12x35	290.6	228.12	336,111	14,237	34.0	7.0	8,403	982	9,363	1,498
950	900x300	H-890x299x15x23	28	212.6	PH-900x300x12x25	252.0	197.82	348,600	11,262	37.2	6.7	7,747	751	8,730	1,156
951		H-900x300x16x28	28	243.2	PH-900x320x12x30	292.8	229.85	422,726	16,396	38.0	7.5	9,394	1,025	10,469	1,566
952		H-912x302x18x34	28	285.7	PH-900x300x12x40	338.4	265.64	499,217	18,012	38.4	7.3	11,094	1,201	12,337	1,830
953		H-918x303x19x37	28	307.2	PH-900x320x15x40	379.0	297.52	542,606	21,868	37.8	7.6	12,058	1,367	13,530	2,094

For structural members (500~900 series) that are sensitive to floor height and require limited depth, it is recommended to use members with depths equal to their nominal dimensions as specified above.

3. Structural Design

How to use MIDAS gen

[Midas Gen V905 R1] Addition of Commercial Pos-H Section DB

- Support for commercial Pos-H section DB
- 869 optimized Pos-H beam types, 84 standardized types

Properties > Section > Section Properties

- The height (H) of the beam is increased by adding the thickness of the flanges (t_f) on both sides to the existing RH shape (Rolled H Beam) height, while the web thickness (t_w) is optimized to be thinner than the web of the RH shape.
- The width (B) of the beam is either the same as the existing RH beam or rounded to the nearest 10mm.
ex) 398, 402, 402, 405, 407, 408 → 400mm
- The flange thickness (t_f) is equal to or greater than that of RH beams.
- All flexural members are compact Section.

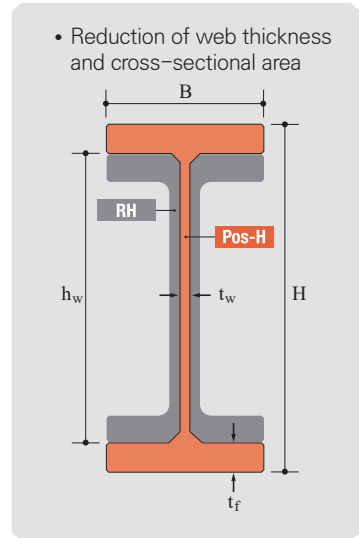

3. Structural Design

```

=====
* SECTION PROPERTIES GENERATED BY MIDAS GEN
Shape = B - Section, (Built-up)
Depth = 0.400, Flg Width = 0.400, Web Center = 0.200
Web Thick = 0.000, Top F Thick = 0.000, Bot. F Thick = 0.000
=====
[[[+]]] CHECK FLEXURAL STRENGTH ABOUT MAJOR AXIS.
-----
( ) Calculate limiting width-thickness ratio of flange for flexure.
[ K03 41 31 00 : 2019 Specification 1.5.3.1, <Table 1.5-1> ]
- Lambda_p = 1.12*sqrt(Es/Fy) = 27.53
- Lambda_r = 1.40*sqrt(Es/Fy) = 34.54
( ) Calculate limiting width-thickness ratio of web for flexure.
[ K03 41 31 00 : 2019 Specification 1.5.3.1, <Table 1.5-1> ]
- Lambda_p = 2.42*sqrt(Es/Fy) = 59.71
- Lambda_r = 5.70*sqrt(Es/Fy) = 140.53
( ) Check width-thickness ratio of flange (BTR).
[ K03 41 31 00 : 2019 Specification 1.5.3.1, <Table 1.5-1> ]
- BTR = 1.000 < Lambda_p, OK
( ) Check width-thickness ratio of web (BTR).
[ K03 41 31 00 : 2019 Specification 1.5.3.1, <Table 1.5-1> ]
- BTR = 0.710 < Lambda_p, OK
=====
    
```

```

=====
* SECTION PROPERTIES GENERATED BY MIDAS GEN
Shape = H - Section, (Built-up)
Depth = 0.550, Top F Width = 0.300, Bot. F Width = 0.300
Web Thick = 0.012, Top F Thick = 0.000, Bot. F Thick = 0.000
=====
[[[+]]] CHECK FLEXURAL STRENGTH ABOUT MAJOR AXIS.
-----
( ) Elastic section modulus referred to tension and compression flanges.
- Syc = 0.0049 m3
- Sot = 0.0049 m3
[ K03 41 31 00 : 2019 Specification 4.3.4.2, (4.3-16), (4.3-19) ]
- FL = 0.7*Fy = 241500.0000 kPa. (Sst/Syc > 0.7)
( ) Calculate limiting width-thickness ratio of flange for flexure.
[ K03 41 31 00 : 2019 Specification 1.5.3.1, <Table 1.5-1> ]
- Lambda_p = 0.39*sqrt(Es/Fy) = 9.38
- Lambda_r = 0.685
- FL = 241500.0000 kPa
- Lambda_r = 0.95*sqrt(Es/Fy) = 22.16
( ) Calculate limiting width-thickness ratio of web for flexure.
[ K03 41 31 00 : 2019 Specification 1.5.3.1, <Table 1.5-1> ]
- Lambda_p = 5.70*sqrt(Es/Fy) = 92.97
- Lambda_r = 5.70*sqrt(Es/Fy) = 140.53
( ) Check width-thickness ratio of flange (BTR).
[ K03 41 31 00 : 2019 Specification 1.5.3.1, <Table 1.5-1> ]
- BTR = 0.710 < Lambda_p, OK
( ) Check width-thickness ratio of web (BTR).
[ K03 41 31 00 : 2019 Specification 1.5.3.1, <Table 1.5-1> ]
- BTR = 0.400 < Lambda_p, OK
=====
    
```

3. Structural Design

[midas Gen V905 R1] Addition of commercial Pos-H section DB (continued)

- 953 types of Pos-H steel sections: 734 types for flexural members, 20 types for asymmetric flexural members, 75 types for compression members, 40 types for Double Web compression members, and 84 types for standardized members.
- After Steel Code Check, Pos-H sections can be selected when updating the cross-section.

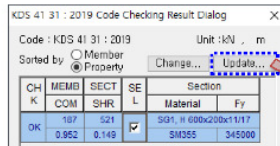
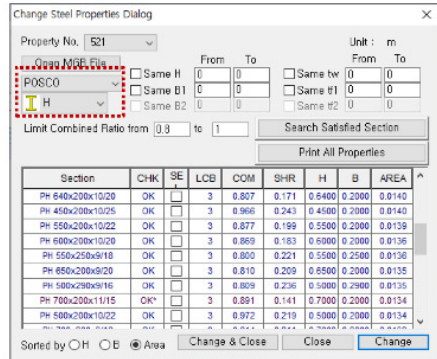
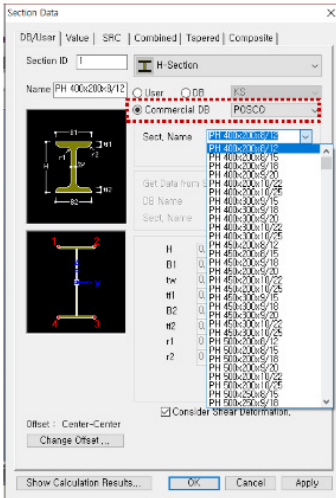

- 953 types of Pos-H steel sections: 734 types for flexural members, 20 types for asymmetric flexural members, 75 types for compression members, 40 types for Double Web compression members, and 84 types for standardized members.
- After Steel Code Check, Pos-H sections can be selected when updating the cross-section.

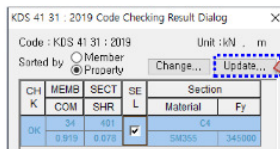
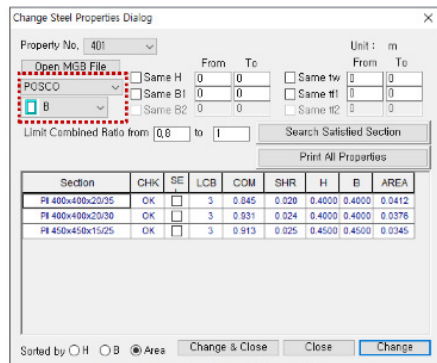
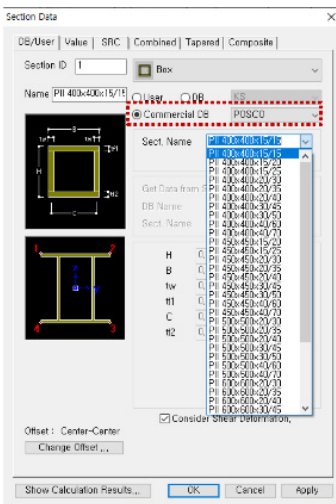

4. Economic Analysis of Pos-H

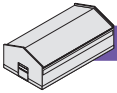

Plant

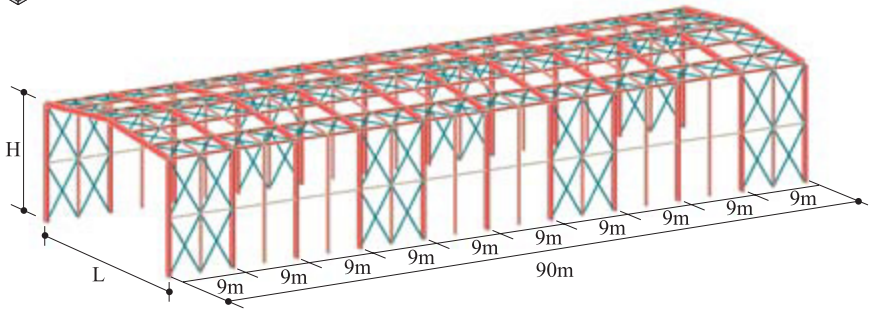

Design conditions

- Dead load : 0.35kN/m²
- Span (L) : 20–40m
- Live load : 1.0kN/m²
- Total length : 90m (10 Bays)
- Eave height (H) : 15m
- Roof slope : 1/10

18~23%

When converting RH to **optimized Pos-H**, the main members achieve a 18–23% reduction in material volume

Members		Steel type	SPAN (L)					
			20m		30m		40m	
			RH(ton)	PH(ton)	RH(ton)	PH(ton)	RH(ton)	PH(ton)
Main members	Main Column	SM355	45.2	36.2	61.0	49.3	94.3	72.2
	Main Girder	SM355	26.5	19.1	55.1	44.2	107.5	93.5
	subtotal		71.7	55.3	116.1	93.5	201.8	165.67
	Weight ratio (PH/RH)			0.77		0.81		0.82
Secondary members	Sub Column	SM275	22.7	22.7	22.7	22.7	22.7	22.7
	Horizontal Beam	SM275	5.3	5.3	5.3	5.3	5.3	5.3
	Roof Beam(1)	SM275	22.3	22.3	31.2	31.2	40.2	40.2
	Roof Beam(2)	SM275	7.8	7.8	11.7	11.7	14.8	14.8
	subtotal		58.1	58.1	70.9	70.9	83.0	83.0
Brace	Wall Brace	SM275	10.3	10.3	10.3	10.3	10.3	10.3
	Roof Brace	SM275	7.6	7.6	14.5	14.5	17.6	17.6
	subtotal		17.9	17.9	24.8	24.8	27.8	27.8
Total			147.7	131.3	211.8	189.2	312.6	276.5
Weight ratio (PH/RH)				0.89		0.89		0.88

Note : Only the main members are changed from RH to PH, while secondary members and braces remain as RH.

4. Economic Analysis of Pos-H

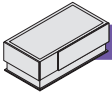

General building

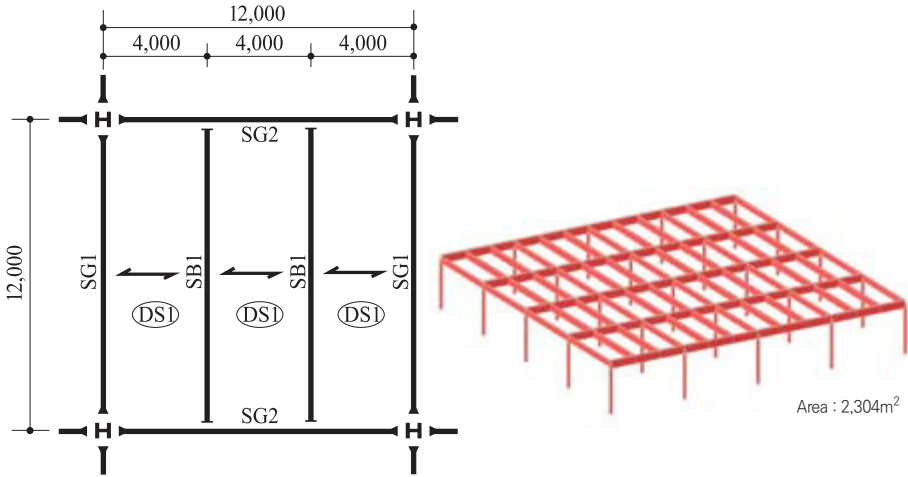

Design conditions

- Dead load : 5.0kN/m²
- Live load : 5.0kN/m²
- Span (L) : 5.3m
- Unbraced length: 4.0m

8%

Converting RH to standardized Pos-H results in 8% material reduction

19%

Converting RH to optimized Pos-H results in 19% material reduction

Members	Steel type	RH		Standardized Pos-H		Optimized Pos-H	
		Section	Weight (ton)	Section	Weight (ton)	Section	Weight (ton)
C1	SM355	H-400x400x13x21	22.8	PH-400x400x16x20	22.6	PH-350x350x15x25	22.9
SG1	SM355	H-612x202x13x23	32.2	PH-640x220x12x20	30.2	PH-650x250x8x15	23.5
SG2	SM355	H-800x300x14x26	50.4	PH-850x320x10x25	45.2	PH-850x350x12x20	44.7
SB1	SM355	H-692x300x13x20	63.8	PH-740x300x10x20	57.3	PH-750x250x9x18	46.5
Total			169.2		155.3		137.6
Weight ratio (PH/RH)					0.92		0.81

Note : Pos-H is denoted as PH

4. Economic Analysis of Pos-H

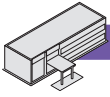

Retail facilities

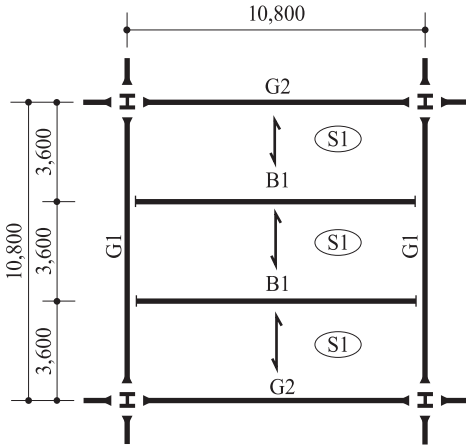

Area : 1,050m² x four stories

- Design conditions**
- Dead load : 5.6kN/m²
 - Live load : 4.0kN/m²
 - Span (L) : 4.5m
 - Unbraced length: 3.6m

7%

Converting RH to **standardized Pos-H** results in 7% material reduction

19%

Converting RH to **optimized Pos-H** results in 19% material reduction

Members	Steel type	RH		Standardized Pos-H		Optimized Pos-H	
		Section	Weight (ton)	Section	Weight (ton)	Section	Weight (ton)
C1	SM355	H-414x405x18x28	66.8	PH-400x400x16x30	66.6	PH-450x450x15x25	64.4
G1	SM355	H-700x300x13x24	95.8	PH-750x290x10x25	87.5	PH-750x350x9x18	77.4
G2	SM355	H-600x200x11x17	54.7	PH-632x210x9x16	49.3	PH-650x200x8x12	39.9
B1	SM355	H-600x200x11x17	82.0	PH-632x210x9x16	74.0	PH-650x200x8x12	59.9
Total			299.3		277.4		241.6
Weight ratio (PH/RH)					0.93		0.81

Note : Pos-H is denoted as PH

5. Quality assurance and Delivery guarantee for Pos-H

Manufacturing Specifications for Pos-H



Quality Inspection of Pos-H

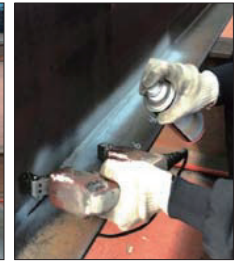

Test of Pos-H



Beam bending test

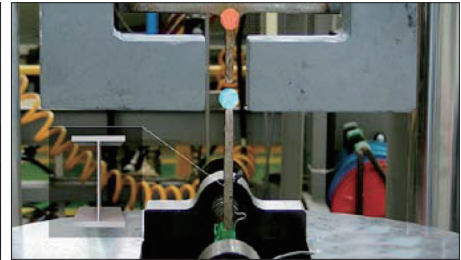

Welding joint tensile test

Delivery time of Pos-H

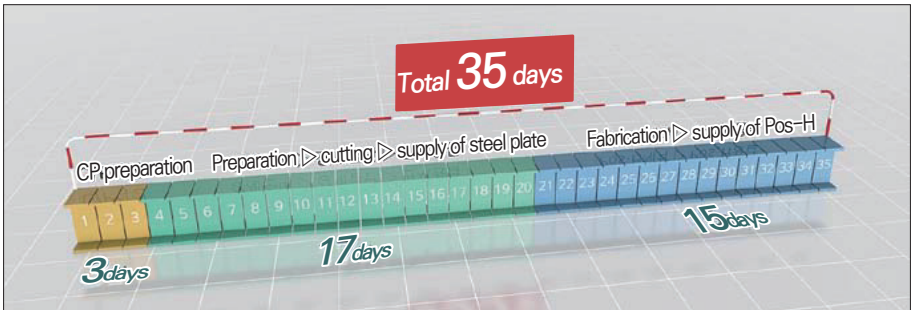

6. Application cases

PyeongChang IBC(International Broadcasting Center)

Building for international broadcast coverage during the 2018 PyeongChang Winter Olympics

- **Construction Location** : Alpensia Resort, Pyeongchang-gun, Gangwon-do
- **Construction Period** : April 2016 ~ April 30, 2017 (12 months)
- **Estimated Construction Cost** : 51.4 billion KRW
- **Construction Scale** : 1 underground floor ~ 5 floors above ground
- **Total Floor Area** : 51,024m²
- Design change from existing RH design (6,460 tons) to Pos-H design (5,950 tons)
- Application case of standardized Pos-H



[Aerial view of the Pyeongchang IBC]

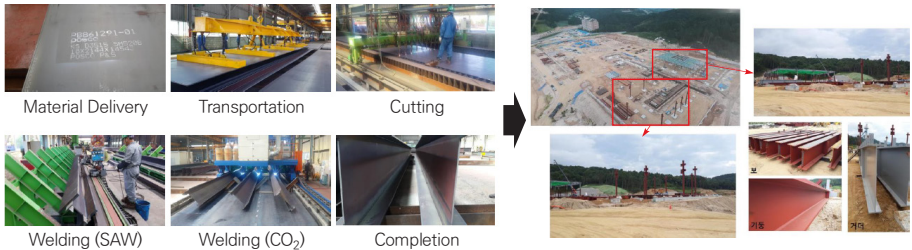

Other examples



[Cheongna City Tower
- Hanyang Construction]



[Doosan Bundang Center
- Doosan Construction]



[Suwon Convention Center
- Hanwha Construction]



[Suwon Starfield
- Shinsegae Construction]



[Yeosu MRO Hub
- S&I Corporation]



[Science Complex
- Shinsegae Construction]



[Heavy Ion Accelerator
- POSCO E&C]



[Uiwang Shopping Mall
- Lotte Construction]



[Sejong City Art Center
- Hanjin Construction]

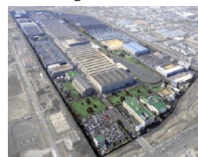

[GM Korea Changwon
- POSCO E&C]



[K-Culture Valley
- CJ Construction]



[LGES Ochang Battery Factory
- GS E&C]

6. Application cases Project list

NO.	Project Name	Date
1	Pyeongchang IBC (International Broadcasting Center)	2016-04-01
2	Taeyangdang Printing Co., Ltd. Anyang Factory	2016-06-10
3	Eunsung Global Wonju Factory V.E	2016-07-01
4	DK UIL Factory Expansion	2016-07-01
5	POSCO Songdo PP Experimental Building	2016-08-01
6	K-Culture Valley Ilsan Complex Performance Hall	2016-08-12
7	Daemyung Daechi-dong Lucen Tower Remodeling	2016-10-01
8	Gyeongin Ara Waterway Incheon Logistics Complex (T3-1)	2016-10-01
9	Gyeongin Ara Waterway Incheon Logistics Complex (T4-1)	2016-10-01
10	Myanmar Steel Bridge (at Yowa)	2017-06-13
11	Suwon Convention Center	2017-07-01
12	Pohang Steel Plate 4CC New Construction	2017-08-01
13	Heavy Ion Accelerator	2018-01-15
14	Asan Hana Materials Factory	2018-03-28
15	Jeongwon Steel New Construction	2018-09-12
16	Doosan Bundang Center	2018-10-01
17	Yeoksam-dong Hyunjeong Building	2018-11-01
18	POSCO ESM Gwangyang Secondary Battery Cathode Material Factory	2018-11-26
19	Gwangmyeong Chung-Ang University Hospital	2019-01-02
20	Shinsegae Daejeon Expo Science Complex (Mixed-use): Hotel + Shopping Mall	2019-01-02
21	U.S. Project (Additions and Alterations for HYUNDAI Power Transformers USA)	2019-02-12
22	Nonhyeon-dong Mixed-use Facility	2019-04-09
23	Sejong City Art Center	2019-04-16
24	Pohang Coal Storage Facility (6 SILO)	2019-04-19
25	GM KOREA Changwon Paint Shop New Construction	2019-05-03
26	RIST Seismic Reinforcement	2019-08-01
27	Hanjin Steel Pipe 2nd Factory	2019-08-01
28	Gwangyang 4th Hot Rolling Mill Facility Improvement Yard Expansion 1st Phase Construction	2019-08-01
29	Yeoju Doojin Logistics Warehouse	2019-11-01
30	Serveone Yeosu MRO HUB Center New Construction Design	2019-11-21
31	Dongchon Plaza (Pohang POSCO)	2019-12-23
32	Lotte Uiwang Complex Shopping Mall New Construction	2020-03-01
33	Yeouido MBC Development Project	2020-05-01
34	POSCO E&C Incubating Center Construction	2020-05-01
35	LGES Ochang 2nd Division Automotive Battery Factory New Construction	2020-06-01
36	POSCO Chemtech Anode Material 2nd Factory (Sejong City)	2020-07-01
37	POSCO On-site Cafeteria	2020-08-01
38	Natural Anode Material 2nd Factory Expansion	2020-08-01

6. Application cases Project list

NO.	Project Name	Date
39	ATG Company Icheon Factory New Construction	2020-09-01
40	POSCO Gwangyang Chemical Plant (Phase 3)	2020-09-30
41	Sinansan Line Construction	2020-10-01
42	Dongkuk Steel KS Standard Expansion Economic Analysis	2020-10-01
43	POSCO Chemical Pohang Artificial Graphite Anode Material Factory	2020-11-01
44	Samyang Pruwel Wonju Factory New Construction	2021-01-02
45	ENG Steel Yesan Factory New Construction	2021-02-01
46	Bongrae 1st District Urban Renewal Redevelopment Project	2021-03-01
47	POSCO Gwangyang Chemical Plant (Phase 4)	2021-05-01
48	POSCO E&C_Samyang Food Miryang Factory	2021-05-01
49	Suwon Starfield	2021-05-01
50	Sinansan Line Construction (POSCO E&C portion)	2021-05-01
51	Danyang Wodeok-ri Beomwoo PC Factory New Construction	2021-09-01
52	Pohang 6 Coke Plant Construction	2021-09-01
53	Goyang Broadcasting Data Center (Equinix Seoul 2)	2021-12-01
54	Pohang Phase 1 Cathode Material Factory New Construction	2022-08-01
55	Busan-Ulsan-Gyeongnam Busan Logistics Center New Construction	2022-08-01
56	POSCO E&C The Sharp Gallery New Construction	2022-09-01
57	POSCO E&C Gwangyang PR Center and Education Center New Construction Project	2022-09-01
58	POSCO E&C Gwangseok Lithium Site	2022-10-01
59	Gwangyang 3rd Steel Plant Slag Yard Expansion Project	2022-12-01
60	Gwangyang Precursor Phase 2	2023-03-01
61	POSCO Nickel Plant	2023-03-01
62	Hyundai Motor Paint Shop New Construction in Arizona, USA	2023-04-01
63	LG Household & Health Care Geumwang Logistics Center New Construction	2023-07-01
64	Pohang Cathode Material 2nd Construction	2023-08-01
65	Acro Yeouido The One Site	2023-11-01
66	Yangso Enclosure Project	2023-12-01
67	Pyeongtaek Jangdang District e-Convenient World City New Construction	2023-12-01
68	POSCO E&C Pohang Talent Creation Center	2024-01-01
69	LGES Ochang Energy Plant 2 Battery Production Building 2 New Construction	2024-02-01
70	Goyang Pungdong C-1-1BL, C1-1-2BL, C-2BL	2024-02-01
71	POSCO Gwangyang Cathode Material Phase 5 New Construction	2024-03-01
72	M-MEK Hyomun Factory New Construction	2024-09-01
73	Busan-Ulsan-Gyeongnam Busan Logistics Center New Construction	2024-10-01
74	HD Hyundai Electric Cheongju Distribution New Factory	2024-12-01
75	Starfield Cheongna New Construction	2024-12-01

7. Intellectual Property rights

Classification	Title	Application Number (Issue Date)	Applicant (Publisher)
Patent	Method for standardizing improved welded assembled H-beams and improved standardized welded assembled H-beams	2021-0025948	Columbus
	Special moment connection with non-scallop	2020-0175618	POSCO
	Beam-column connection for special moment frames with damage control and reusability of beam-column	2020-0127896	POSCO
	Beam-column connection for special moment frames with extended vertical stiffener	2020-0080901	POSCO
	Beam-column connection for special moment frames with improved horizontal stiffener	2020-0050075	POSCO
	Beam-column connection for special moment frames with extended horizontal stiffener	2019-0091785	POSCO
	Method for standardizing welded assembled H-beams and standardized welded assembled H-beams	2017-0068255	Columbus
Copyright	Optimized Pos-H Beam Specification	C-2018-005295	Columbus
Trademark	Pos-H	40-2017-0053734	POSCO
Manufacturing Guidelines	Pos-H Special Specifications Manufacturing Guidelines	2016.11.30	POSCO KSSC
Design Manual	Design Manual of Special Moment Frames using Pos-H	20252.1	POSCO KSSC KSEA LERA
Report	Beam Height 1,100mm & 1,500mm Pos-H Beam Special Moment Connection (NS)	2023.1.31	POSCO KSSC
	Beam Height 1,200mm & 1,500mm Pos-H Beam Special Moment Connection (LHS)	2023.1.31	
	Beam Height 1,000mm Pos-H Beam Special Moment Connection (NS)	2020.1.2	
	Beam Height 1,000mm Pos-H Beam Special Moment Connection (IHS)	2020.1.2	
	Beam Height 1,000mm Pos-H Beam Special Moment Connection (LHS)	2020.1.2	
	Performance Verification Study of Pos-H Members	2017.2.21	
Technical Articles	Development of Special Moment Frame Using 1,500mm Deep Pos-H Beam	2022.6	AIK
	Characteristics and Application Technology of Low Yield Point Steel HSA80 (Reuse Special Moment Connection)	2021.2	KSSC
	Special Moment Connection Using 1,000mm Deep Pos-H Beam	2017.2.21	
Academic paper	Special Moment Frame Technology for 1,500mm Deep Pos-H Beams	2024.6	KSSC
	Special Moment Frame with 1,000mm Pos-H Beam	2022.6	
	Special Moment Connection Using Pos-H with 1,000mm Beam Depth	2020.1	
SCI paper	Experimental study on lengthened horizontal stiffened moment connections with deep jumbo beams for special moment frames	2025.2 (submission)	Engineering Journal
	Experimental verification of seismic performance of built-up beam-to-column connections with ductile detail	2021.1	Journal of Constructional Steel Research
Certification	Pos-H special moment connection with Non-Scallop (NS) for beam depths of 1,100mm and 1,500mm	2023.4.28	Certifying Organization : KSSC
	Pos-H special moment connection with Lengthened Horizontal Stiffener (LHS) for beam depths of 1,200mm and 1,500mm	2023.4.28	
	Pos-H special moment connection with Non-Scallop (NS) for beam depths of 1,000mm	2020.4.6	
	Pos-H special moment connection with Improved Horizontal Stiffener (IHS) for beam depths of 1,000mm	2020.4.6	
	Pos-H special moment connection with Lengthened Horizontal Stiffener (LHS) for beam depths of 1,000mm	2020.4.6	

7. Intellectual Property rights



[Patent Certificate]



[Copyright]

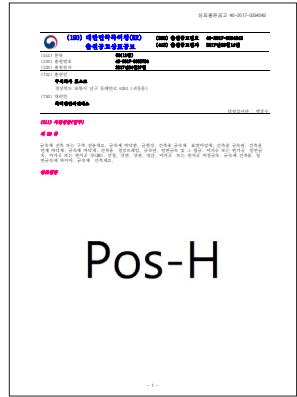

[Trademark Rights]

7. IP rights



[SCI]

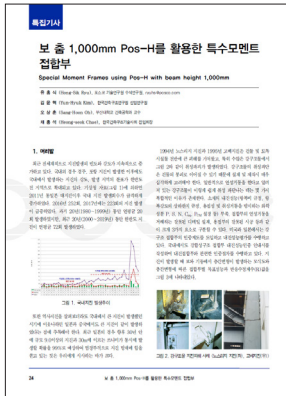

[Technical Article]

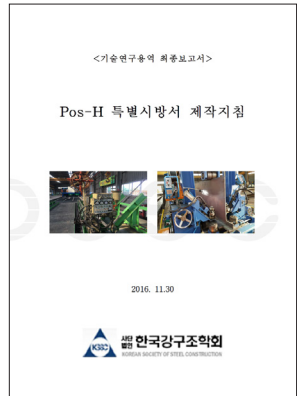

[Production Guidelines]

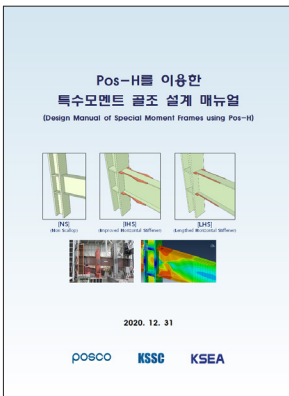

[SMF Design Manual]

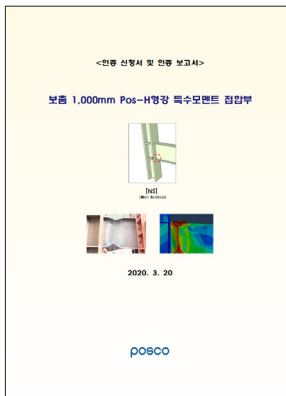

[SMF Report]



[SMF Certificate]

[Appendix] Special Moment Frame Design

Definition of Special Moment Frame

- ① The connection shall be capable of developing a story drift ratio of at least 0.04 rad.
- ② The measured flexural strength of the connection at the column face shall be at least 80% of the beam M_p (nominal plastic moment capacity) at a story drift ratio of 0.04 rad.

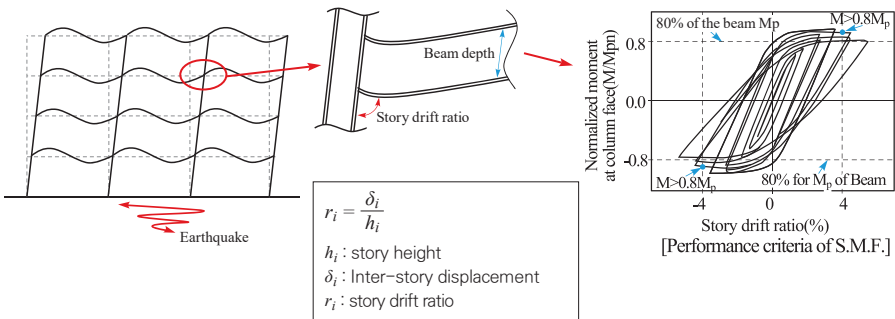

Advantages of Special Moment Frame

- ① **Design** : Significantly reduce base shear force by setting the response modification factor R to 8
- ② **Seismic Performance** : Achieve a safe building even in strong earthquakes of magnitude 7.0 or higher
- ③ **Economic Efficiency** : Reduce material quantity through seismic performance [RH Normal(100%) → PH Special(75%)]
- ④ **Manufacturability** : Reduce manufacturing costs when producing joints compared to existing weld access holes
- ⑤ **Constructability** : Same as existing methods with on-site construction of brackets in the typical column tree format

– base shear force :

$$V_i = C_s \cdot W \left\{ \begin{array}{l} C_s \text{ (seismic response coefficient)} \\ W : \text{building weight} \end{array} \right. = \frac{S_{D1}}{\left[\frac{R}{I_E} \right] T} \left\{ \begin{array}{l} S_{D1} : \text{Design spectral acceleration} \\ R : \text{Response modification factor} \\ T : \text{Fundamental period of the building} \\ I_E : \text{Importance factor of the building} \end{array} \right.$$

Connection types	Story drift ratio	Response modification factor (R)
Ordinary Moment Frame	minimum	3.5
Intermediate Moment Frame	2%	4.5
Special Moment Frame	4%	8.0

[Appendix] Special Moment Frame Design

Comparative Experiment of Beam–Column Connections Applying Pos-H vs SHN

- Pos-H is the only system in the world that achieves special moment resistance for beams with a depth of 1,500mm
- Pos-H is the world's first to develop a special moment frame for large beams with a depth of 1,500mm

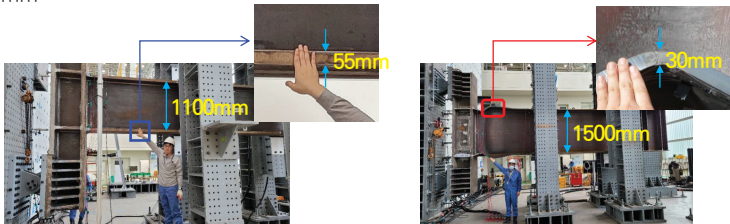

[Pos-H Applied connection test]

(PH-1,500mm applied 5% deformation → Special Moment Connection)

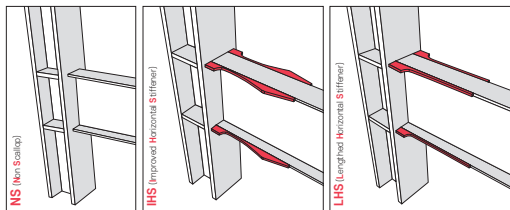

[Special Moment Frame Certified Connection]

Special Moment Frame Design Case Study

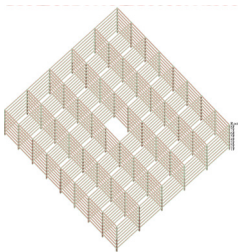

Classification	Details
Number of Floors	8 floors above ground
Floor Height	5m for all floors / Total building height: 40m
Purpose	Office facility
Structure	Steel frame
Dead Load	5.1 kN/m ²
Live Load	3.0 kN/m ²
Soil Profile Type	S ₄

8-story office building (O.M.F. vs I.M.F. vs S.M.F.)

Category	O.M.F	I.M.F	S.M.F
RH Volume (ton)	822.6	763.5 (7%)	721.1 (12%)
Pos-H Volume (ton)	726.9 (11%)	664.5 (19%)	612.4 (25%)

➔ Reference: 'Design Manual for Special Moment Frames Using Pos-H'
(Authors: POSCO, KSSC, KSEA, LERA, LEHIGH UNIVERSITY ATLSS CENTER)



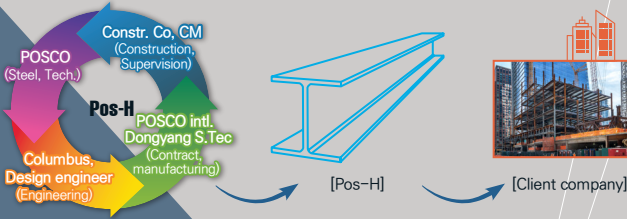

posco

Marketing Department

TEL : 02)3457-1780 / E-mail : fantian@posco.com

TEL : 02)3457-1190 / E-mail : seho1213@posco.com

TEL : 02)3457-1194 / E-mail : dahan.park@posco.com

R&D center

TEL : 032) 200-2428 / E-mail : ryuhs@posco.com

Orders and Technical Support

Columbus

Engineering Division

TEL : 02) 555-5377 / FAX : 02)555-5388

E-mail : station@clbs.co.kr / www.clbs.co.kr

Marketing Division

TEL : 010-7773-1809 / victorytiger68@daum.net

posco

INTERNATIONAL

Marketing Department

TEL : 02) 759-3019 / E-mail : thkim0714@poscointl.com

Dongyang S-Tech

Marketing Department

TEL : 02) 2619-1611, 010-2438-3048 / E-mail : greatchoo@nate.com